

NEC

PI-321
ISSUE 6.00

UNIVERGE SV8300

Configuration Guide

8300R6

June 2011

NEC Corporation

LIABILITY DISCLAIMER

NEC Corporation reserves the right to change the specifications, functions, of features, at any time, without notice.

NEC Corporation has prepared this document for use by its employees and NEC subsidiary. The information contained herein is the property of NEC Corporation and shall not be reproduced without prior written approval from NEC Corporation.

Copyright 2009

NEC Corporation

Printed in Japan

All brand names and product names on this document are trademarks or registered trademarks of their respective companies.

< Definition >

Following shows the meaning of terms of product name used in this document.

Terms in this document	Product Names Used in Market
IVS	NEAX 2000 IVS, NEAX7400 M80VS / M100 / M110 / M120
IVS ²	NEAX 2000 IVS ² , NEAX7400 M100MX, NEAX 2000 INTEGRATED VOICE SERVER
IPS	NEAX 2000 IPS, UNIVERGE NEAX 2000 IPS
SV8300	UNIVERGE SV8300

Note: This document explains SV8300 system configuration and its required equipment for all markets except for Japan. There is some discrepancy between the markets due to the technical specifications and/or market requirements. Therefore, if there is a description only for particular market, it is defined by remarks such as "for US", "for Australia" etc. If there is no remark, the description is common for all markets.

REVISION TABLE (1/2)

ISSUE	DATE	DESCRIPTION	APPROVED BY	PREPARED BY
1.0	Jun 2008	8300R1	Y. Matsuoka	S. Asano H. Shirai
1.1	Aug 2008	8300R1 Update Major updates as follows; 1) Added Appendix 1 – 3. 2) Revised Tables 4-2, 4-4, 6-9, 8-1 and 9-1.	Y. Matsuoka	H. Shirai
1.2	Sep 2008	8300R1 Update Major updates as follows; 1) Added Table 8-2. 2) Revised Tables 4-2 and 9-1. 3) Revised Appendix 2.	Y. Matsuoka	H. Shirai
2.0	Oct 2008	8300R2 and Update Major updates as follows; 1) Appendix 3	Y. Matsuoka	H. Shirai
2.1	Jan 2009	8300R2 Update Major updates as follows; 1) CD-PVAA (for US) added	Y. Matsuoka	H. Shirai
3.0	Jun 2009	8300R3 and Update Major updates as follows; 1) Revised Table 5-2 and 9-1. 2) Added Table 8-2.	Y. Matsuoka	H. Shirai
3.01	Aug 2009	8300R3 Update Major updates as follows; 1) Added / updated the following connections in Chapter 6; - PMS on RS-232C connection - Alarm Display Connection - TAS Equipment Connection etc. 2) Revised Table 4-4. 3) Revised Appendix 3.	Y. Matsuoka	H. Shirai
3.50	Dec 2009	8300R3.5 and Update Major updates as follows; 1) Revised Figure 2-1 2) Added network requirement between UNITS in Chapter 6.12 3) Revised Table 9-1	Y. Matsuoka	H. Shirai
4.00	May 2010	8300R4 and Update Major updates as follows; 1) Revised Table 4-2 2) Added CD-SVRU (for US)	Y. Matsuoka	H. Shirai

REVISION TABLE (2/2)

ISSUE	DATE	DESCRIPTION	APPROVED BY	PREPARED BY
4.01	Aug 2010	8300R4 Update Major updates as follows; 1) Revised Figure 1-1 (SP350) 2) Revised Table 3-2 (NP0.8-12 battery) 3) Revised Table 3-4 (NP0.8-12 battery) 4) Revised Table 4-1 (PZ-BS10) 5) Revised Table 4-3 (for US) 6) Added Table 6-5 7) Revised Appendix 1 (SN1764 CYGME and CD-SVRU)	A. Yamamoto	M. Inaba
5.00	Nov 2010	8300R5 and Update Major updates as follows; 1) Revised Table 4-1, 4-2, 4-5 and 9-1	A. Yamamoto	M. Inaba
5.01	Jan 2011	8300R5 Update Major updates as follows; 1) Revised Table 6-5, 8-2 and 9-1	A. Yamamoto	M. Inaba
6.00	June 2011	8300R6 and Update Major updates as follows; 1) Add Figure 1-4 (Failover) 2) Revised Table 4-4,(BHA)	A. Yamamoto	M. Inaba

UNIVERGE SV8300 Configuration Guide

TABLE OF CONTENTS

1. Introduction.....	6
2. System Configuration	11
3. Chassis and Battery Box	13
3.1 1U Chassis	13
3.2 2U CP Chassis (Dual CPU Chassis).....	15
3.3 2U Chassis	17
3.4 Battery Box.....	19
4. Circuit Boards.....	20
4.1 General.....	20
4.2 Common Control Blades	21
4.3 Legacy Line/Trunk Blades and Application Blades	25
5. Installation Type	33
5.1 Floor Mounting Installation	34
5.2 Wall Mounting Installation	35
5.3 19 inch Rack Mounting Installation	36
5.4 Desktop Mounting Installation	37
5.5 Floor Mounting / Desktop Mounting Installation with Stand.....	38
6. Cabling	40
6.1 Inter-Chassis Connection.....	40
6.2 CSI Synchronization Cable Connection.....	41
6.3 AC Cord Connection.....	42
6.4 Battery Cable Connection	43
6.5 Desk Console Connection.....	49
6.6 PCPro Connection.....	50
6.7 SMDR / Hotel Printer / MCI / PMS Connection.....	52
6.8 Alarm Display Connection	53
6.9 TAS Equipment Connection	54
6.10 External Paging Connection.....	54
6.11 External Music Source Connection	55
6.12 IP Connection.....	56
7. Software	59
8. License.....	60
9. System Capacity	65
9.1 Traffic Capacity.....	65
9.2 System Port Capacity.....	66
Appendix 1: MTBF	68
Appendix 2: Maximum Power Consumption	69
Appendix 3: Cable Length of Terminals	70

LIST OF FIGURES

	Page
Figure 1-1 Simplified View of the SV8300 System Connectivity	6
Figure 1-2 SV8300 CPU Blade Configuration	8
Figure 1-3 SV8300 Dual CPU System.....	9
Figure 1-4 SV8300 Failover Mode.....	10
Figure 2-1 Example of System Configuration (IP-oriented System)	11
Figure 2-2 Example of System Configuration (TDM-oriented System).....	12
Figure 3-1 1U Chassis (Front View)	13
Figure 3-2 1U Chassis (Rear View)	13
Figure 3-3 2U CP Chassis (Front View)	15
Figure 3-4 2U CP Chassis (Rear View).....	15
Figure 3-5 2U Chassis (Front View)	17
Figure 3-6 2U Chassis (Rear View).....	17
Figure 4-1 Location of Common Control Blades (1U Chassis)	21
Figure 4-2 Location of Common Control Blades (2U CP Chassis)	22
Figure 4-3 Location of Legacy Line/Trunk Blades and Application Blades (2U Chassis)	25
Figure 5-1 Floor Mounting Installation	34
Figure 5-2 Wall Mounting Installation	35
Figure 5-3 19 inch Rack Mounting Installation	36
Figure 5-4 Desktop Mounting Installation	37
Figure 5-5 Floor Mounting / Desktop Mounting Installation with Stand.....	38
Figure 6-1 Inter-Chassis Connection.....	40
Figure 6-2 CSI Synchronization Cable Connection.....	41
Figure 6-3 AC Cord Connection.....	42
Figure 6-4 Built-in Battery Connection.....	43
Figure 6-5 External Battery Connection (45 minutes backup)	45
Figure 6-6 External Battery Connection (3 hours backup)	46
Figure 6-7 External Battery Connection w/o Battery Box.....	47
Figure 6-8 Desk Console Connection.....	49
Figure 6-9 PCPro Direct Connection	50
Figure 6-10 PCPro Remote Connection (via internal modem of VMDB)	50
Figure 6-11 PCPro Remote Connection (via external modem).....	51
Figure 6-12 SMDR / Hotel Printer / MCI / PMS Direct Connection	52
Figure 6-13 SMDR / MCI / PMS Remote Connection (via external modem)	53
Figure 6-14 Alarm Display Connection	53
Figure 6-15 TAS Equipment Connection	54
Figure 6-16 External Paging Connection.....	54
Figure 6-17 External Music Source Connection – Built-in MoH Port	55
Figure 6-18 External Music Source Connection – Paging Adapter.....	55
Figure 6-19 IP Connection (IP System or Multi-UNIT configuration).....	57
Figure 6-20 IP Connection (TDM System with 1-UNIT configuration)	57
Figure 6-21 Internal Chassis Connection (2U CP Chassis)	58

LIST OF TABLES

	Page
Table 3-1 Specifications of 1U Chassis	14
Table 3-2 1U Chassis and its Related Equipment	14
Table 3-3 Specifications of 2U CP Chassis	15
Table 3-4 2U CP Chassis and its Related Equipment	16
Table 3-5 Specifications of 2U Chassis	17
Table 3-6 2U Chassis and its Related Equipment	18
Table 3-7 Specifications of Battery Box	19
Table 3-8 Battery Box and its Related Equipment	19
Table 4-1 Common Control Boards	24
Table 4-2 Legacy Line/Trunk Blades and Application Blades	26
Table 4-3 Board Power Factor	28
Table 4-4 Terminal Power Factor	28
Table 4-5 VoIPDB Channels Required in Each Call Connection	30
Table 4-6 Calculation Method of VoIPDB (Recommended)	30
Table 4-7 SIP Converter Channels Required in Each Call Connection	31
Table 5-1 Hardware for Floor Mounting Installation	34
Table 5-2 Hardware for Wall Mounting Installation	35
Table 5-3 Hardware for 19 inch Rack Mounting Installation	36
Table 5-4 Hardware for Desktop Mounting Installation	37
Table 5-5 Hardware for Floor Mounting / Desktop Mounting Installation with Stand	39
Table 6-1 CSI Synchronization Cable	41
Table 6-2 AC Cord	42
Table 6-3 Built-in Battery Cable	44
Table 6-4 External Battery Cable w/o Battery Box	47
Table 6-5 Battery Capacity of External Battery w/o Battery Box	47
Table 6-6 PCPro Connection Cable	50
Table 6-7 PCPro Remote Connection Cable (via external modem)	51
Table 6-8 SMDR / Hotel Printer / MCI Direct Connection Cable	52
Table 6-9 SMDR / MCI Remote Connection Cable (via external modem)	53
Table 6-10 NIC Port Setting by Application	56
Table 6-11 Network Requirement for inter-UNIT/Remote-UNIT connections	58
Table 7-1 Software	59
Table 8-1 License	60
Table 8-2 Required Licenses	62
Table 8-3 Required System Port Capacity Licenses	64
Table 9-1 System Port Capacity	66

1. Introduction

The SV8300 is a full-featured IP based communications system providing a rich feature set of existing NEAX2000 IPS, with pure Voice over IP (VoIP) communications, across corporate Local and Wide Area Networks (LAN and WAN).

DT700 series telephones are designed to provide a converged infrastructure at the desktop, with a 10/100BASE-TX connection to the LAN and built-in hub for a PC connection to the telephone itself. The SV8300 can provide peer-to-peer connections between DT700 series telephones with voice compression, offering existing D^{term}IP (series i) telephone features with an enhanced user interface. On the WAN side, the system can provide peer-to-peer connections over IP networks with voice compression, on a CCIS basis (CCIS over IP) or Remote UNIT (Remote UNIT over IP).

Besides, the SV8300 can provide legacy line/trunk interfaces to support the existing Time Division Multiplexing (TDM) based infrastructure, such as analog telephones, digital telephones (DT300 series), analog networks and digital networks (T1, ISDN etc.). The legacy line/trunk blades can be accommodated in the 2U Chassis.

At maximum configuration, the system can provide 2048 ports in standalone configuration or Remote UNIT network configuration.

Communications between legacy stations / trunks and DT700 series telephones / IP networks are made via the VoIPDB, which converts packet-based voice data to TDM-based voice data, and vice versa. Both peer-to-peer connections and TDM-based connections are controlled by the CPU blade. The CPU incorporates a built-in Device Registration Server (DRS) and a single interface point for IP connection to IP telephone, PCPro and OAI / ACD servers. Figure 1-1 shows a simplified view of the SV8300 system connectivity.

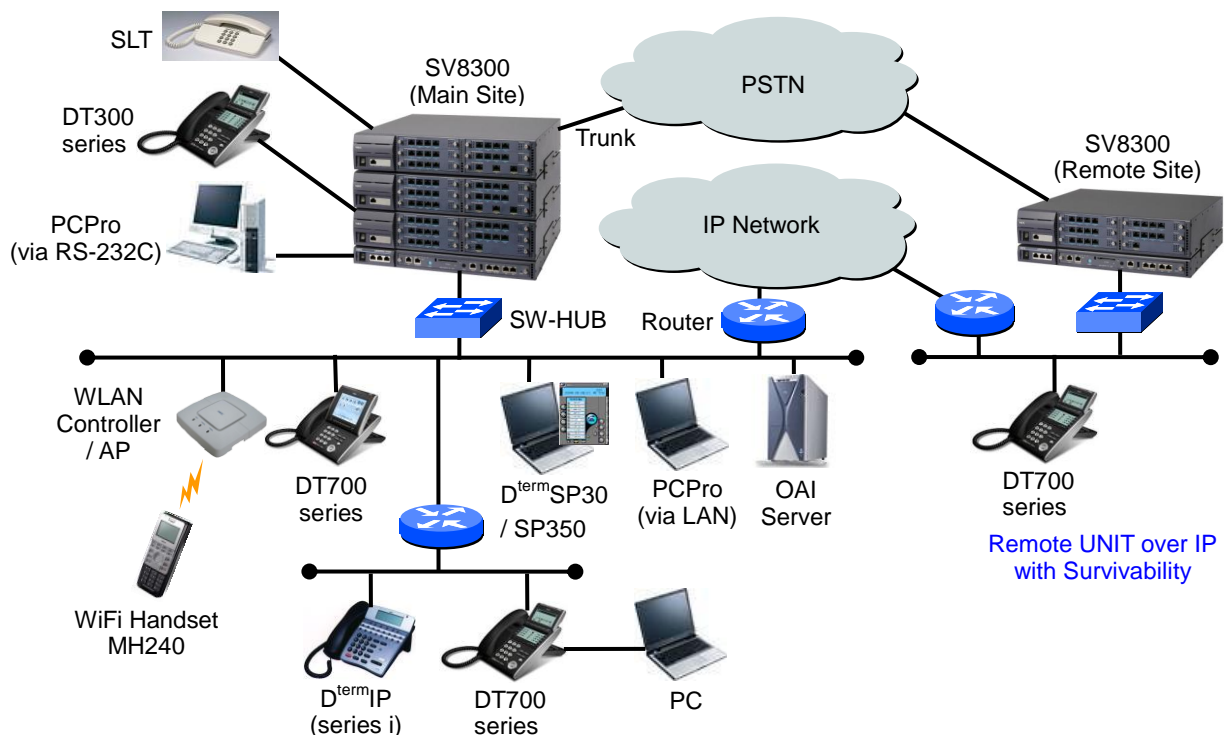

Figure 1-1 Simplified View of the SV8300 System Connectivity

Highlights of the SV8300 are as follows:

■ Pure IP System capable TDM configuration

The SV8300 supports both pure IP switching (peer-to-peer connections) and Time Division Switching. The pure IP switching is provided for communications between DT700 series telephones and for CCIS / Remote UNIT connections with other SV8300 (CCIS over IP or Remote UNIT over IP) / SV7000 (CCIS over IP). On the other hand, the TDM switching is provided for communications between legacy stations/trunks. Connection between IP network and legacy network is made via VoIPDB on the CPU blade, which converts packet-based voice data to TDM-based voice data, and vice versa.

■ Powerful CPU Blade with Built-in Functionalities

The CPU blade of the SV8300 is the heart of pure IP connections and TDM-based connections. The CPU blade employs an Intel® Celeron® M 600MHz Processor. With this processing power and DSP technology, it integrates the following functions, which are provided by additional card slots in the previous NEAX2000 IPS. Some of these functions are managed with software license.

- DTMF receivers
- Caller ID receivers
- Caller ID senders
- MF / MFC senders / receivers
- Conference trunks
- VMDB (Note)
- VoIPDB

DB = Daughter Board

In addition, by means of today's advanced LSI technology, size of the CPU Blade is minimized, Maintenance port (Fast Ethernet) is built in and VoIPDB which has VoIP port (Gigabit Ethernet) is mountable without additional slots in the Chassis. The Maintenance port is linked with LAN / WAN for inter-work with PCPro, OAI, SMDR, PMS and SNMP, and the VoIP port is linked with LAN / WAN for control signaling and voice signaling (RTP) for DT700 series, PCPro, OAI, SMDR, PMS, SNMP etc.

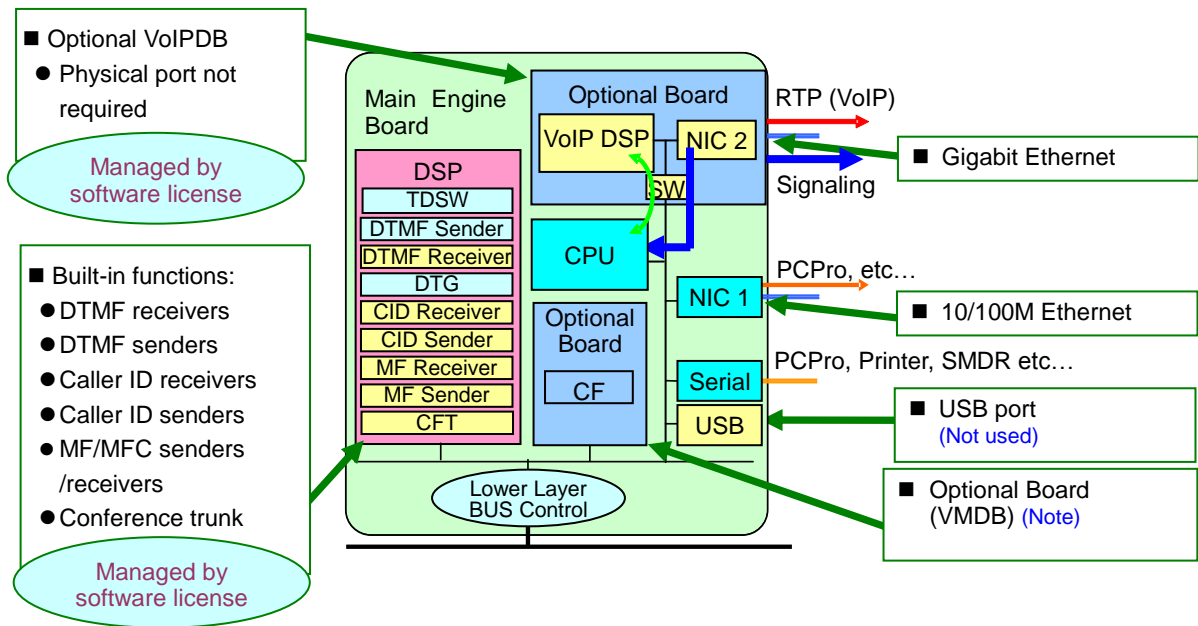

Figure 1-2 SV8300 CPU Blade Configuration

(Note) The following features are available with the optional board (VMDB).

- Modem (V.34)
- Speech Synthesis (English/Japanese/Korean/Chinese) (SV83 VOICE DATA CF(SS) required)
- VRS (120 sec. x 8 messages) (SV83 VOICE DATA CF(SS) required)

■ High Density Legacy Line/Trunk Blades

Major legacy line/trunk blades used in SV8300 are provided with main board + daughter board architecture. When the main board is only mounted in an initial supply, line/trunk interfaces can be easily expanded by adding the daughter board. The maximum number of circuits for the line/trunk blades is 16/eight circuits with daughter board, respectively. This allows the physical system size to be compact.

■ Universal Blade Slot (2U Chassis)

2U Chassis are used for legacy line/trunk blades. One 2U Chassis provides six universal blade slots. Also, these blade slots can be used for application blades without complicated limitations. As this makes for easy quotation and installation.

■ Large System Capacity

SV8300 provides maximum 2048 ports in standalone configuration or Remote UNIT network configuration – 1536 ports for extension lines (DT700 series, DT300 series, SLT etc.) and 512 ports for trunks (SIP Trunk, ISDN, COT etc.).

■ Easy Installation (Front Cabling and Enhanced O&M Tool)

Cable connectors (RJ-45 or RJ-61) are located on the front panel of each chassis and blade. It increases efficiency of the cabling work.

Also, PCPro provides enhanced user interface. Quick Setup tool provides easy setup (system data programming) for a basic system configuration in shorter time.

■ Remote UNIT over IP with Survivability

SV8300 can provide Remote UNIT configuration, main site and remote site(s) through IP network. The main site controls call processing and service features access for station users located in both main site and remote site(s). When the remote site cannot be connected with main site due to IP network failure or main site failure, the remote site initializes the system and re-starts operation by its own CPU (survival mode). In the survival mode, almost service features are provided to the station users accommodated in the remote site. When IP network / main site is recovered, the remote site can be restored to normal mode with system initialization by manual operation or automatically (Selectable by system data setting).

■ Dual CPU System

SV8300 can provide a Dual CPU System with two CPU blades. One CPU runs as active and another runs as standby. The CPU with redundancy enables the SV8300 to uplift the system reliability. The system employs cold standby system. When a failure is detected in the active CPU, standby CPU restarts initialization and changes into active CPU. Two CPU blades can be mounted on UNIT01 only.

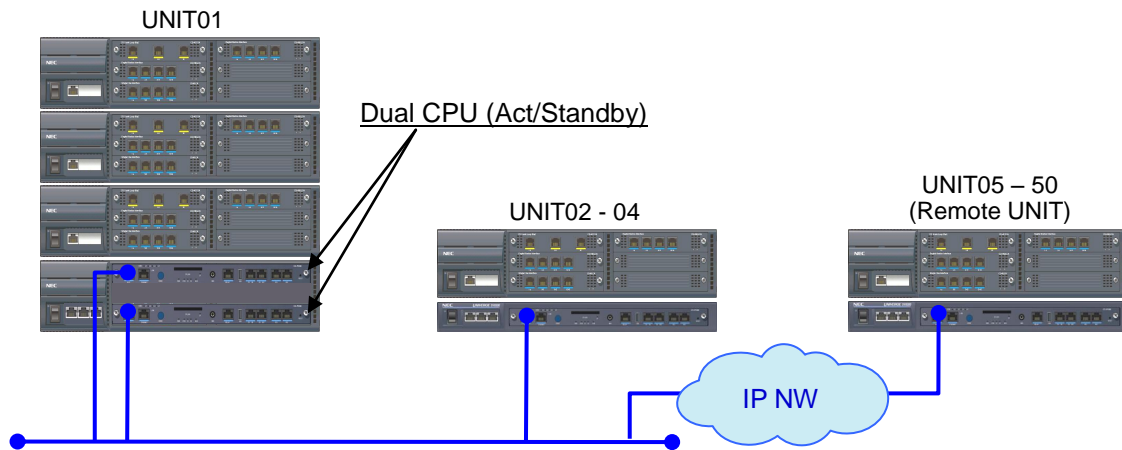

Figure 1-3 SV8300 Dual CPU System

■ Failover Mode Support

The SV8300 supports Failover mode with Secondary UNIT that consists of 1U Chassis. A Secondary UNIT is prepared as a standby unit in Remote UNIT over IP system, and the Secondary UNIT automatically takes over UNIT01 operation in the event of IP network disconnection/CPU or power failure in UNIT01. This feature enables the system to continue the operation as a single system. This feature employs cold standby processing that will reset the system at the changeover from Primary UNIT (Main UNIT) to Secondary UNIT.

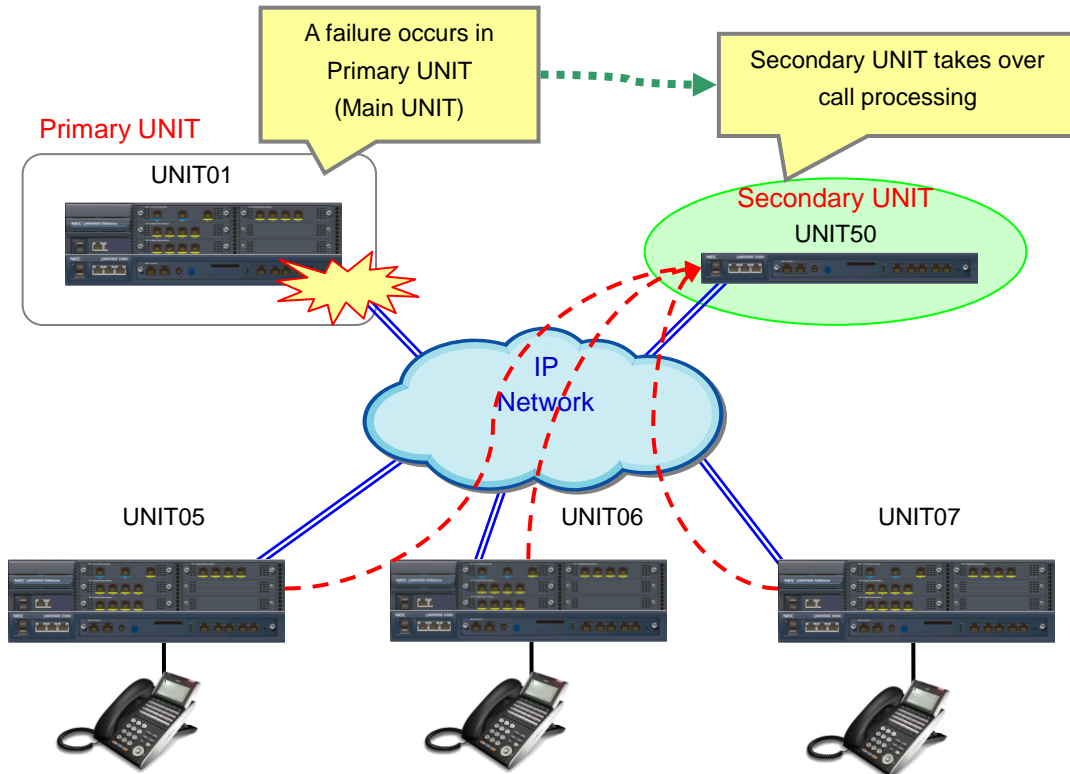

Figure 1-4 SV8300 Failover Mode

2. System Configuration

SV8300 consists of 1U Chassis/2U CP Chassis and 2U Chassis depending on the system configuration.

1U Chassis/2U CP Chassis mounts CPU blade, BUS Interface Blade, Power Supply Unit (PSU) and Cooling FAN.

2U Chassis mounts various Legacy Line/Trunk Blades, Application Blades, BUS Interface Blade, PSU and Cooling FAN.

The CPU blade in 1U Chassis/2U CP Chassis can control a maximum of three 2U Chassis; this configuration is called a "UNIT". The SV8300 can be configured for maximum of four-UNIT.

Figure 2-1 and Figure 2-2 show examples of maximum system configuration for IP-oriented system and TDM-oriented system, respectively.

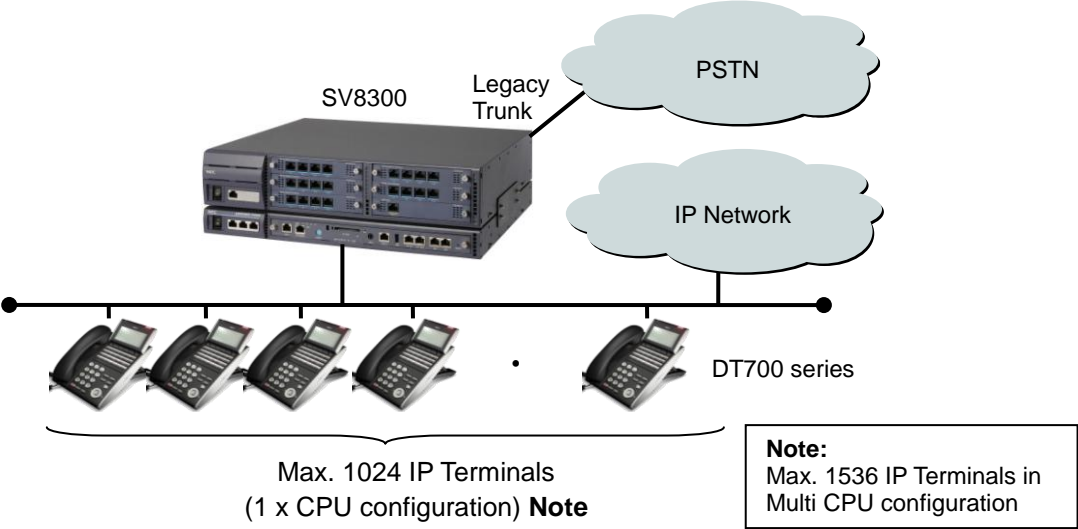

Figure 2-1 Example of System Configuration (IP-oriented System)

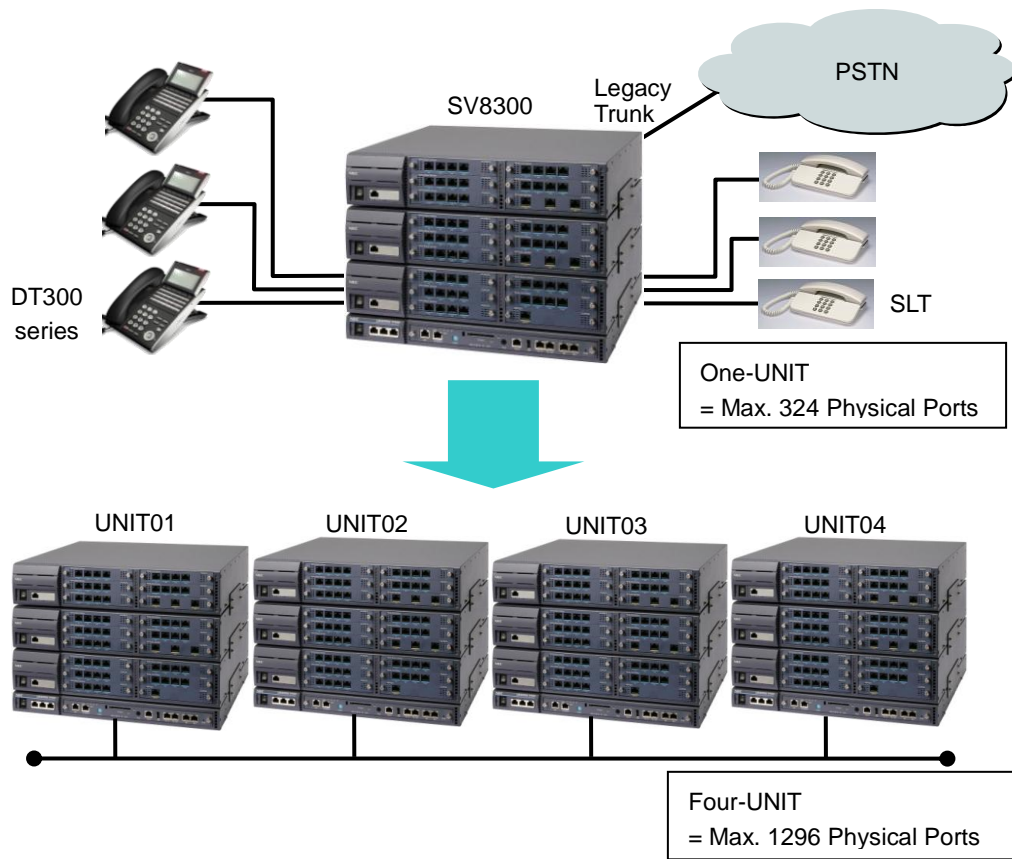

Figure 2-2 Example of System Configuration (TDM-oriented System)

3. Chassis and Battery Box

There are three types of Chassis, 1U Chassis, 2U CP Chassis and 2U Chassis.

- The 1U Chassis mounts the CPU blade, BUS Interface Blade, Power Supply Unit (PSU), Cooling FAN and optional short-term backup batteries.
The 1U Chassis is used in UNIT01 - 50 on single mode CPU configuration or UNIT02 – 50 on Dual CPU configuration.
- The 2U CP Chassis (Dual CPU Chassis) mounts the CPU blades, BUS Interface Blade, PSU, Cooling FAN and optional short-term backup batteries.
The 2U CP Chassis is used in UNIT01 on Dual CPU configuration.
- The 2U Chassis has six universal blade slots for Legacy Line/Trunk Blades (Analog Line Circuits (LC), Digital Line Circuits (DLC), Central Office Trunks (COT), ISDN PRI Trunks (PRT), etc.) and Application Blades. It also houses the BUS Interface Blade, PSU, Cooling FAN and optional short-term backup batteries.

Instead of the built-in batteries, an optional Battery Box is available for long-term backup batteries.

3.1 1U Chassis

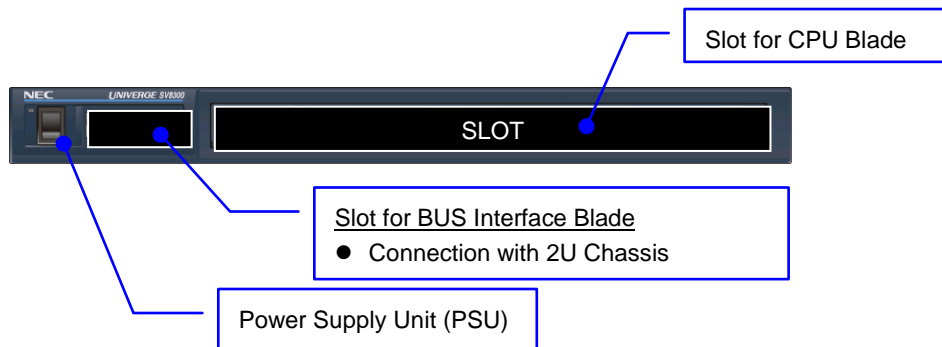

Figure 3-1 1U Chassis (Front View)

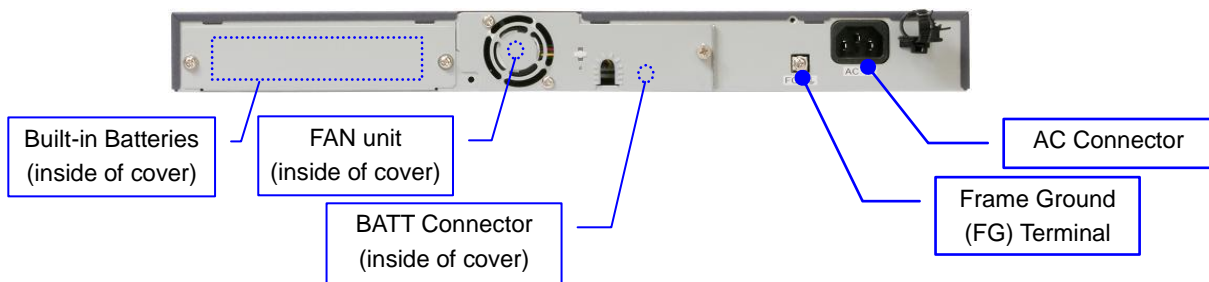

Figure 3-2 1U Chassis (Rear View)

Table 3-1 Specifications of 1U Chassis

Item	Specification
Dimensions (W x D x H)	430mm (16.9 inch) x 400mm (15.7 inch) x 43mm (1.7 inch)
Weight	Approx. 5.0 Kg (176.4 oz) (when all slots occupied, however, no built-in battery included)
Input Power	AC 100V – 240 V (Automatically adjusted)
Slot	BUS Slot + CPU Slot
Operating Conditions	Ambient Temperature: 0 – 40 degree centigrade (When the ambient temperature will exceed this value during the holiday or the night, an air conditioner is required.) Relative Humidity: Less than 90% (non-condensing)
Cooling	Cooling by FAN

In addition, short-term (about 10 minutes) backup battery can be mounted in each Chassis.
2 x 12V-0.8AH batteries are available for 1U Chassis.

Table 3-2 1U Chassis and its Related Equipment

Description	B Code	Feature	SV 8300	SV 8100
SN1752 CYGMB	---	1U Chassis (BWB / PSU / FAN included)	X	-
CHS BLANK SLOT COVER KIT(BUS)	BE106853	Blank slot cover for BUS slot	X	-
CHS1U FAN BOX SET	BE106728	FAN Unit for 1U Chassis (for Maintenance)	X	-
PZ-PW146	BE106730	Power Supply Unit (PSU) for 1U Chassis (for Maintenance) (for US)	X	-
PE12V0.8 battery (GS Yuasa) or equivalent	---	Short-term built-in battery for 1U Chassis (Provided locally) ● 12V-0.8AH ● Tyco.1-480318 connectors ● 2 x PE12V0.8 batteries required per 1U Chassis	X	-
NP0.8-12 battery (GS Yuasa) or equivalent	---	Short-term built-in battery for 1U Chassis (Provided locally) ● 12V-0.8AH ● Optional Tyco. 1-480318-0 connectors recommended When standard JST SVH-21T-P1.1 connectors applied, PZ-M710 additionally required ● 2 x NP0.8-12 batteries required per 1U Chassis	X	-
CHS1U BATT MTG KIT-A	BE107382	Short-term built-in battery mount kit for 1U Chassis	X	-

3.2 2U CP Chassis (Dual CPU Chassis)

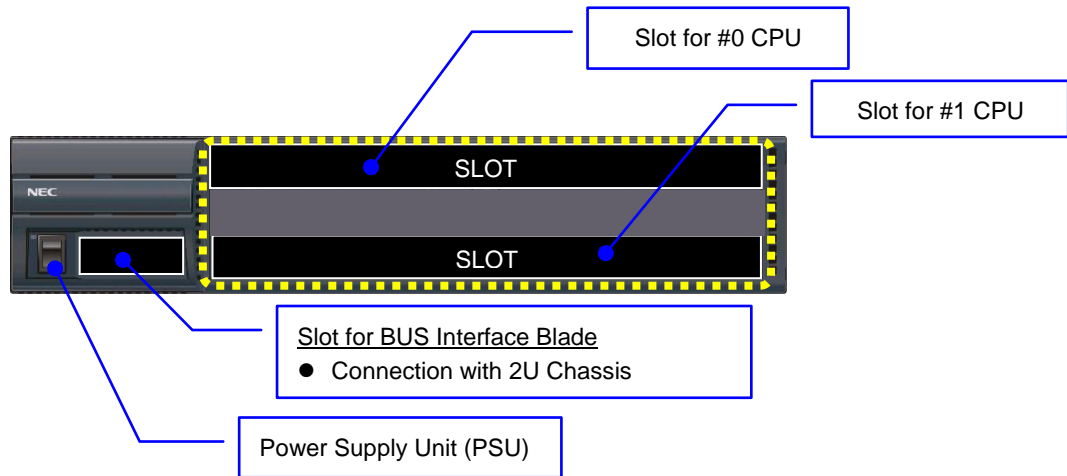

Figure 3-3 2U CP Chassis (Front View)

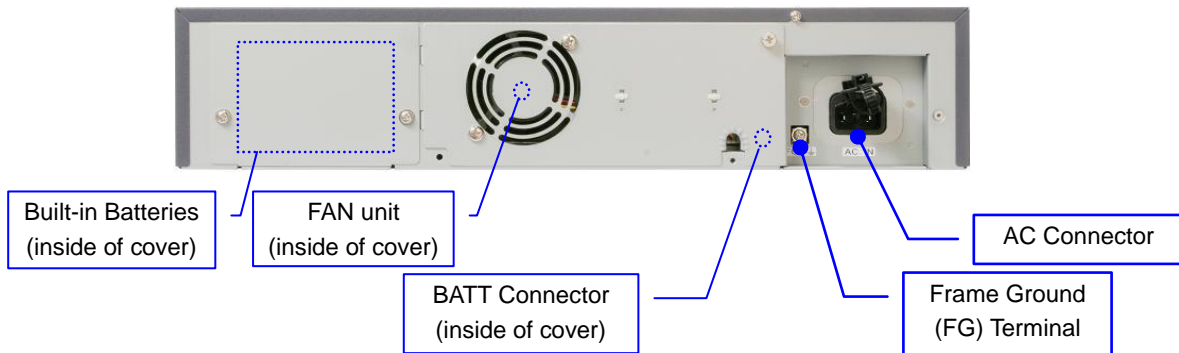

Figure 3-4 2U CP Chassis (Rear View)

Table 3-3 Specifications of 2U CP Chassis

Item	Specification
Dimensions (W x D x H)	430mm (16.9 inch) x 400mm (15.7 inch) x 88mm (3.5 inch)
Weight	Approx. 7.4 Kg (261.0 oz) (when all slots occupied, however, no built-in battery included)
Input Power	AC 100V – 240 V (Automatically adjusted)
Slot	BUS Slot + 2 CPU Slots
Operating Conditions	Ambient Temperature: 0 – 40 degree centigrade (When the ambient temperature will exceed this value during the holiday or the night, an air conditioner is required.) Relative Humidity: Less than 90% (non-condensing)
Cooling	Cooling by FAN

In addition, short-term (about 10 minutes) backup batteries can be mounted in a Chassis. 4 x 12V-0.8AH batteries are available for the 2U CP Chassis.

Table 3-4 2U CP Chassis and its Related Equipment

Description	B Code	Feature	SV 8300	SV 8100
SN1764 CYGME	---	2U CP Chassis (BWB / PSU / FAN included)	X	-
CHS BLANK SLOT COVER KIT(BUS)	BE106853	Blank slot cover for BUS slot	X	X
CHS2U(D) FAN BOX SET	BE109996	FAN Unit for 2U CP Chassis (for Maintenance)	X	-
MPS7101	BE108044	Power Supply Unit (PSU) for 2U CP Chassis / 2U Chassis (for Maintenance) (for US)	X	X
NP0.8-12 battery (GS Yuasa) or equivalent	---	Short-term built-in battery for 2U CP Chassis (Provided locally) <ul style="list-style-type: none"> ● 12V-0.8AH ● JST SVH-21T-P1.1 connectors ● 4 x NP0.8-12 batteries required per 2U CP Chassis 	X	-
CHS2U(D) BATT MTG KIT	BE109995	Short-term built-in battery mount kit for 2U CP Chassis Including; <ul style="list-style-type: none"> ● 1 x Battery mount kit w/ JST connector board ● 1 x DUAL CPU BATT CA INT-A Battery Cable (350mm (1.1ft.)) 	X	-

3.3 2U Chassis

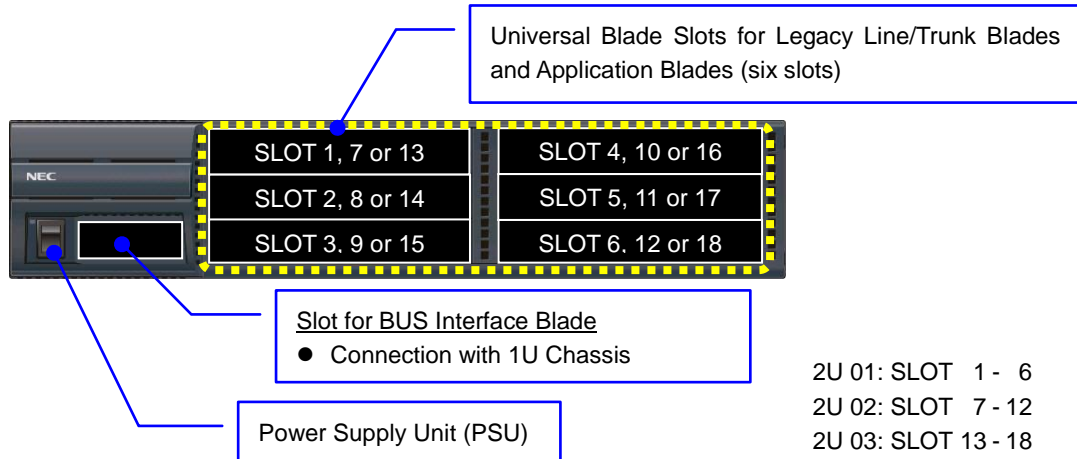

Figure 3-5 2U Chassis (Front View)

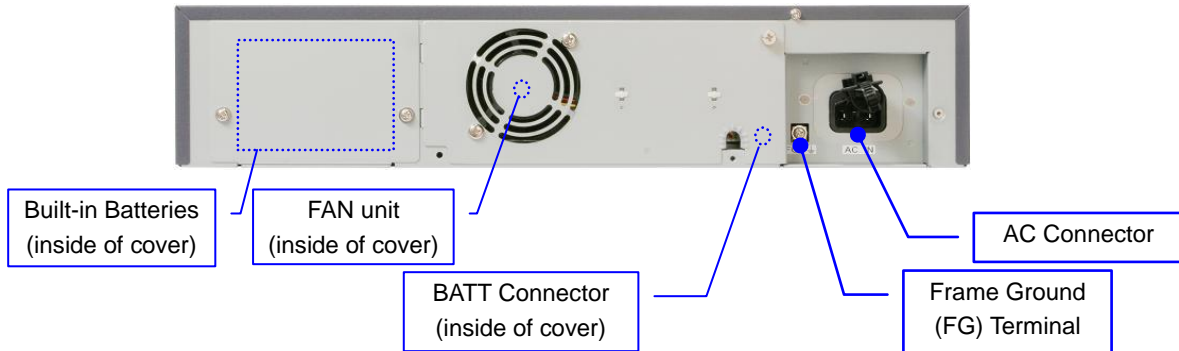

Figure 3-6 2U Chassis (Rear View)

Table 3-5 Specifications of 2U Chassis

Item	Specification
Dimensions (W x D x H)	430mm (16.9 inch) x 400mm (15.7 inch) x 88mm (3.5 inch)
Weight	Approx. 8.2 Kg (289.2 oz) (when all slots occupied, however, no built-in battery included)
Input Power	AC 100V – 240 V (Automatically adjusted)
Slot	BUS Slot + 6 option Slots
Operating Conditions	Ambient Temperature: 0 – 40 degree centigrade (When the ambient temperature will exceed this value during the holiday or the night, an air conditioner is required.) Relative Humidity: Less than 90% (non-condensing)
Cooling	Cooling by FAN

In addition, short-term (about 10 minutes) backup batteries can be mounted in each Chassis.
 2 x 12V-2.3AH batteries are available for the 2U Chassis.

Table 3-6 2U Chassis and its Related Equipment

Description	B Code	Feature	SV 8300	SV 8100
SN1750 CYGMA	---	2U Chassis (BWB / PSU / FAN included)	X	X
CHS2U BLANK SLOT COVER KIT	BE106415	Blank slot cover for universal blade slot (1 / blank slot)	X	X
CHS BLANK SLOT COVER KIT(BUS)	BE106853	Blank slot cover for BUS slot	X	X
CHS2U FAN BOX SET	BE106729	FAN Unit for 2U Chassis (for Maintenance)	X	X
MPS7101	BE108044	Power Supply Unit (PSU) for 2U CP Chassis / 2U Chassis (for Maintenance) (for US)	X	X
NP2.3-12 battery (GS Yuasa) or equivalent	---	Short-term built-in battery for 2U Chassis (Provided locally) <ul style="list-style-type: none"> ● 12V-2.3AH ● JST Faston tab 187 connectors ● 2 x NP2.3-12 batteries required per 2U Chassis 	X	X
CHS2U BATT MTG KIT	BE106403	Short-term built-in battery mount kit for 2U Chassis	X	X

3.4 Battery Box

Instead of the short-term backup battery built-in each 1U/2U Chassis, an external Battery Box is available for long-term (45 minutes – 3 hours) backup batteries.

Table 3-7 Specifications of Battery Box

Item	Specification
Dimensions (W x D x H)	430mm (16.9 inch) x 364mm (14.3 inch) x 132 mm (5.2 inch)
Weight	Approx. 10 Kg (352.7 oz) (when no battery included)
Battery Tray	3 sets of 2 x FML1270 batteries (or equivalent) mountable

Table 3-8 Battery Box and its Related Equipment

Description	B Code	Feature	SV 8300	SV 8100
CHS LARGE BATT BOX	BE106908	Max. 3 sets of 2 x FML1270 batteries mountable per CHS LARGE BATT BOX Including; <ul style="list-style-type: none"> ● 3 x Cable (Blue) 230mm ● 3 x Cable (Black/Red) 460mm ● 4 x Cable (Black/Red) 2060mm Chassis – BATT BOX (JST Faston tab 187 connectors) ● 2 x Upper joint bracket ● 8 x Screw M4 	X	X
FML1270 battery (Furukawa Battery) or equivalent	---	Long-term external battery for 1U/2U CP Chassis and 2U Chassis <i>(Provided locally)</i> <ul style="list-style-type: none"> ● 12V-7AH ● JST Faston tab 187 connectors ● Max. 3 sets of 2 x FML1270 mountable per CHS LARGE BATT BOX 	X	X

The cabling is shown in Chapter 6.4 (2).

4. Circuit Boards

4.1 General

The SV8300 has the following three types of circuit boards. Most of the circuit boards are commonly used for the SV8300 and SV8100.

- Common Control Blades
 - CPU Blade
 - VMDB
 - VoIPDB
 - BUS Interface Blade

- Legacy Line/Trunk Blades
 - Analog Line Circuit (LC)
 - Digital Line Circuit (DLC)
 - Central Office Trunk (COT)
 - ISDN PRI Trunk (PRT), etc.

- Application Blades
 - In-skin Server Blade
 - In-skin UMS Blade
 - In-skin Router Blade
 - In-skin HUB Blade, etc.

4.2 Common Control Blades

Most of the Common Control Blades are mounted in 1U Chassis/2U CP Chassis as follows.

1U Chassis

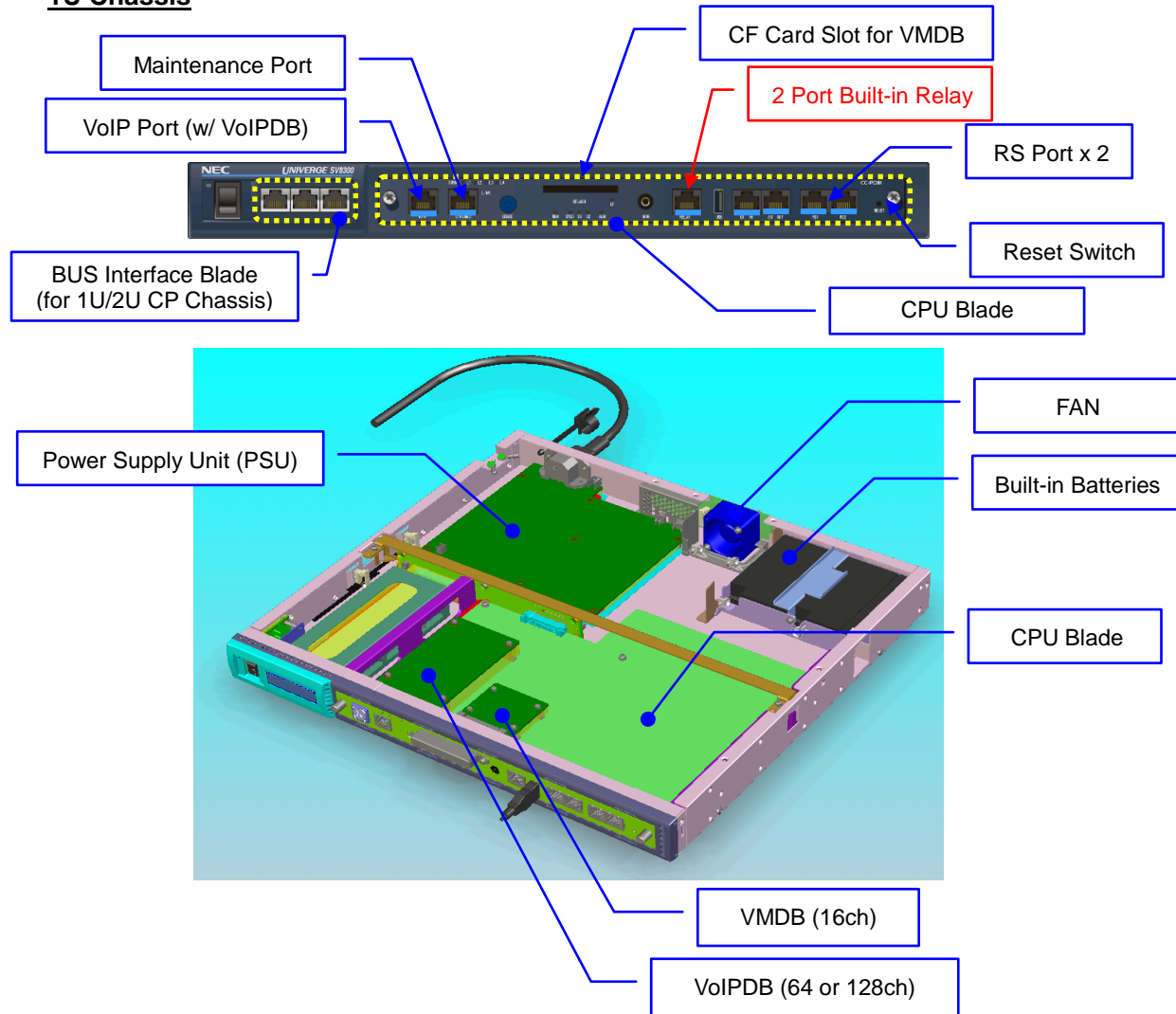

Figure 4-1 Location of Common Control Blades (1U Chassis)

2U CP Chassis

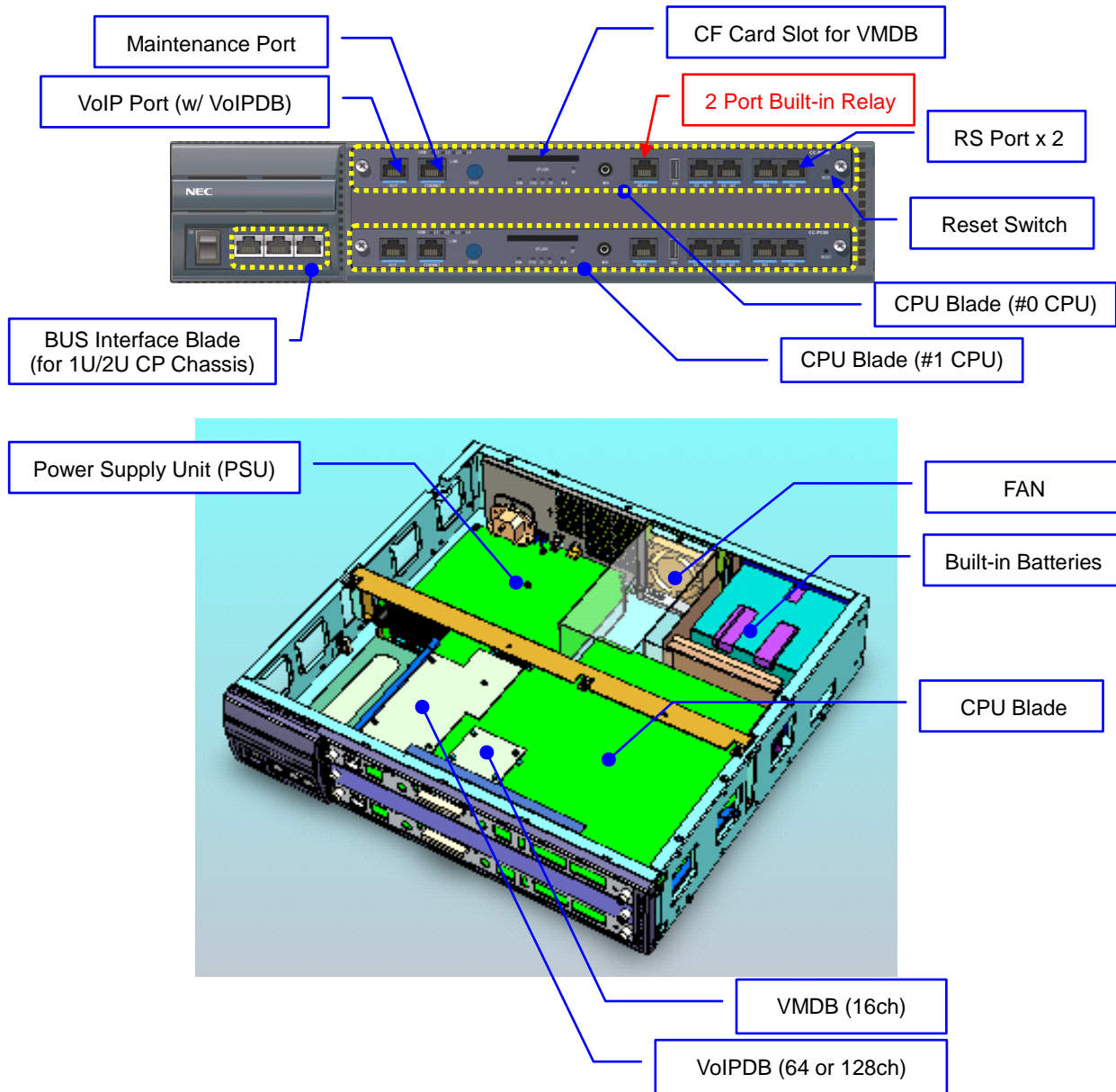

Figure 4-2 Location of Common Control Blades (2U CP Chassis)

(Note) On Dual CPU configuration, there are the following limitations for the configuration.

- RS-232C ports, Relay port and EX IN / EX OUT port on either #0 CPU or #1 CPU can be used.
- #0 CPU and #1 CPU should be configured the same, Example: mounting of VoIPDB, VMDB and Compact Flash Card if required.

There are two types of BUS Interface Blades. One is mounted in the 1U Chassis/2U CP Chassis, and another is mounted in the 2U Chassis. For the BUS Interface Blade mounted in the 2U Chassis, please refer to Chapter 4.3 for the mounting location.

Major specifications and functionality of the CPU Blade are shown below:

- Central Processor: Intel Celeron-M 600MHz
- System Memory: DDR SDRAM 256MB
Flash ROM 64MB
Backup SRAM 4MB
- DSP Function: Tone Generation
DTMF Sender / Receiver
MF / MFC Sender / Receiver
Caller ID Sender / Receiver
Time Switch Control
Conference Trunk
- 3-/4-Party Conference: 16 circuits
- Music-on-Hold: 8 melodies (Note)
- Mini Jack: 1 port for external music source for Music-on-Hold (Note)
- Ethernet Interface: 10/100BASE-TX x 1 port (Maintenance Port)
10/100/1000BASE-T x 1 port (VoIP Port (w/ VoIPDB))
- Serial Interface: RS232C (RJ-45) x 2 ports (for PCPro, SMDR, MCI, Printer or PMS)
- Modem Interface: V.34 modem x 1 port (w/ VMDB)
- USB Interface: USB1.1/2.0 x 1 port (Not used)
- PLO Function
- Built-in SMDR (via RS-232C or LAN)
- Built-in MCI (via RS-232C)
- Built-in PMS (via LAN or RS-232C)
- VRS: Built-in VRS x 8 circuits (max. 30sec./message)
or VRS x 8 circuits (max. 120sec./message) w/ VMDB and SV83 VOICE DATA CF(SS)
- DK x 2 circuits (relay drive only)
- FTP-based MP Program Download from PCPro (on-line mode / off-line mode)

DSP: Digital Signal Processor

DTMF: Dual Tone Multi Frequency

PLO: Phase Lock Oscillator

Note: In case of D^{term}IP (series i) / DT700 series, synthesized melody is provided built in to the phone itself.

The following table shows Common Control Boards available in the SV8300.

Table 4-1 Common Control Boards

Category	Description	B Code	Feature	Daughter Board	SV 8300	SV 8100
CPU	CC-CP01	---	CPU blade for SV8300 Commonly used for single/dual mode CPU configuration	PZ-VM21 PZ-64IPLA PZ-128IPLA	X	-
	CC-CP31	---	CPU blade for SV8300 (Especially used for UNIT02 - 50) (for US/Australia)	PZ-64IPLA PZ-128IPLA	X	-
VM	PZ-VM21	BE106339	VMDB with V.34 modem	None	X	X
	SV83 VOIVE DATA CF(SS)	BE107747	Compact Flash 512MB of VMDB for the following features; - Speech Synthesis feature (English, Japanese, Korean and Chinese) - VRS (120sec. x 8 messages)	None	X	-
VoIP	PZ-64IPLA	BE106340	64ch VoIP Daughter Board	None	X	X
	PZ-128IPLA	BE106341	128ch VoIP Daughter Board	None	X	X
BUS	PZ-BS10	BE106342	BUS Interface Blade for 1U Chassis / 2U CP Chassis	None	X	X
	PZ-BS11	BE106343	BUS Interface Blade for 2U Chassis (1 x BUS cable attached)	None	X	X

4.3 Legacy Line/Trunk Blades and Application Blades

The Legacy Line/Trunk Blades and the Application Blades are mounted in the 2U Chassis.

2U Chassis

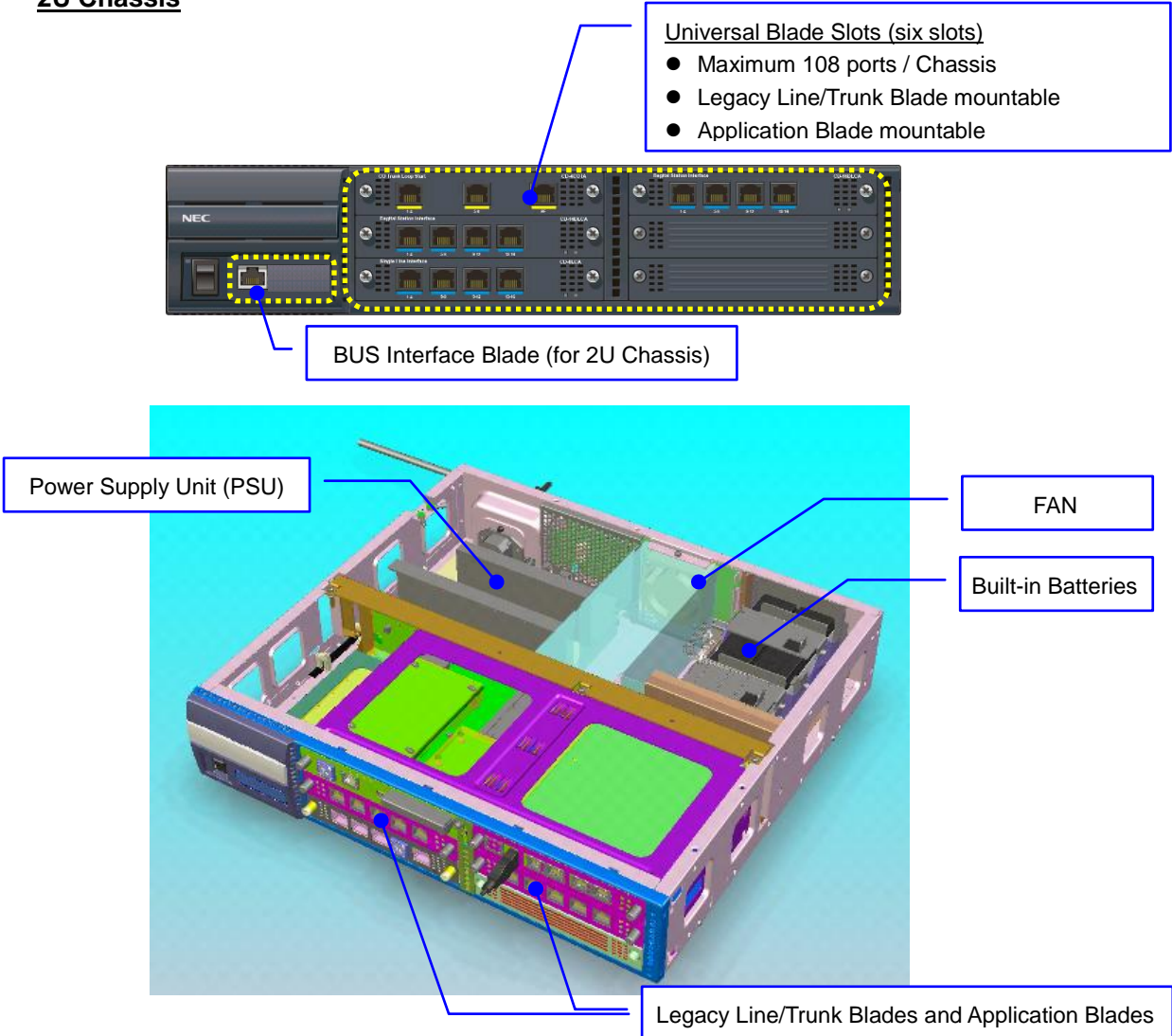

Figure 4-3 Location of Legacy Line/Trunk Blades and Application Blades (2U Chassis)

The following table shows Legacy Line/Trunk Blades and Application Blades available in the SV8300.

Table 4-2 Legacy Line/Trunk Blades and Application Blades

Category	Description	B Code	Feature	No. of Physical Ports (HWCH)	Daughter Board	SV 8300	SV 8100
DLC	CD-8DLCA	BE106344	8L Digital Line Circuit Blade	16 (Note 3)	PZ-8DLCB	X	X
	PZ-8DLCB	BE106416	8L Digital Line Circuit Daughter Board	- (Note 3)	None	X	X
	CD-16DLCA	BE106345	16L Digital Line Circuit Blade	16	None	X	X
LC	CD-4LCA	BE106346	4L Analog Line (SLT) Circuit Blade with MW and Caller ID (Note 1)	16 (Note 3)	PZ-4LCA PZ-8LCE	X	X
	CD-8LCA	BE106348	8L Analog Line (SLT) Circuit Blade with MW and Caller ID (Note 1)	16 (Note 3)	PZ-4LCA PZ-8LCE	X	X
	PZ-4LCA	BE106347	4L Analog Line (SLT) Circuit Daughter Board with MW and Caller ID (Note 1)	- (Note 3)	None	X	X
	PZ-8LCE	BE106349	8L Analog Line (SLT) Circuit Daughter Board with MW and Caller ID	- (Note 3)	None	X	X
COT	CD-4COTA	BE106350	4L Central Office Trunk Blade (Loop-start) with Caller ID (Note 2) (Power failure transfer circuit x 2 included)	8 (Note 3)	PZ-4COTE	X	X
	PZ-4COTE	BE106352	4L Central Office Trunk Daughter Board (Loop-start) with Caller ID (Note 2)	- (Note 3)	None	X	X
	CD-4COTC	BE107077	4L Central Office Trunk Blade (Loop-start) with Caller ID (Note 2) (for Australia) (Power failure transfer circuit x 2 included)	8 (Note 3)	PZ-4COTG	X	X
	PZ-4COTG	BE107078	4L Central Office Trunk Daughter Board (Loop-start) with Caller ID (Note 2) (for Australia)	- (Note 3)	None	X	X
	CD-4COTB	BE106353	4L Central Office Trunk Blade (Loop/Ground-start) with Caller ID (Note 2) (for US) (Power failure transfer circuit x 2 included)	8 (Note 3)	PZ-4COTF	X	X
	PZ-4COTF	BE106354	4L Central Office Trunk Daughter Board (Loop/Ground-start) with Caller ID (Note 2) (for US)	- (Note 3)	None	X	X
BRT / ILC	CD-2BRIA	BE106355	2L ISDN BRI Trunk / 2L ISDN Line Circuit Blade	8 (Note 3)	PZ-2BRIA	X	X
	PZ-2BRIA	BE106356	2L ISDN BRI Trunk / 2L ISDN Line Circuit Daughter Board	- (Note 3)	None	X	X

(to be continued in next page)

Table 4-2 Legacy Line/Trunk Blades and Application Blades (cont'd)

Category	Description	B Code	Feature	No. of Physical Ports (HWCH)	Daughter Board	SV 8300	SV 8100
PRT / DTI	CD-PRTA	BE106359	ISDN PRI Trunk (23B+D) / QSIG Trunk Blade	24	None	X	X
			ISDN PRI Trunk (30B+D) / QSIG Trunk Blade	32			
			T1 DTI Trunk Blade (Note 3)	24			
			E1 DTI Trunk Blade (for Brazil/Australia) (Note 3)	32			
CCT	CD-CCTA	BE106337	CCIS Interface (1.5M) Blade	24	None	X	-
			CCIS Interface (2M) Blade	32			
Analog Trunk	CD-4DIOPA	BE106360	4L Direct Inward Dialing Trunk / Loop Dial Trunk / Long Line Circuit Blade (for US)	4	None	X	X
	CD-4DIOPB	BE106899	4L Direct Inward Dialing Trunk / Loop Dial Trunk / Long Line Circuit Blade	4	None	X	X
	CD-4ODTA	BE106361	4L E&M-2W/4W Trunk Blade (for US)	4	None	X	X
	CD-4ODTB	BE106900	4L E&M-2W/4W Trunk Blade	4	None	X	X
CSI	CD-4CSIB-A	BE107878	4ch ZT Interface Blade (U-interface) (for US/Latin America)	12	None	X	-
APL	CD-RTB	BE106419	In-skin Router Blade	-	None	X	X
	CD-ETIA	BE106420	8-port in-skin HUB Blade PoE (802.3af) supported	-	None	X	X
	CD-VM00	BE106421	In-skin Server / In-skin UMS Blade	16	None	X	X
	CD-PVAA	BE106422	Conference Bridge Blade (for US/Australia)	16	None	X	X
	CD-SVRU	---	Application Blade (for US)	-	None	X	X

(Note 1) MW (Message Waiting) supports "High Voltage method" only. Caller ID (for Single Line Telephone) supports "Bellcore-FSK" and "ETSI-FSK".

(Note 2) Caller ID (from Analog Trunk) supports "Bellcore-FSK" and "ETSI-DTMF".

(Note 3) For the line/trunk blades capable of main board + daughter board architecture, even if only the main board is mounted on the 2U Chassis, the following number of physical ports is forcibly assigned for the SLOT mounted. It is not changed by adding the daughter board.

- DLC: 16 (e.g. CD-8DLCA: 16, CD-8DLCA + PZ-8DLCB: 16)
- LC: 16
- COT: 8
- BRT / ILC: 8

(Note 4) The preinstalled firmware should be updated to the DTI firmware (either T1 or E1) by executing the blade firmware update.

Conditions for Equipment Calculation

1. Limitation of Power Capacity

There are two types of power factors, Board Power Factor and Terminal Power Factors. Each power factor has an upper limit in each 2U Chassis and the total has to be within the limitations.

Table 4-3 Board Power Factor

Board Power Factor (Total has to be "7" or less in each 2U Chassis)	
Blade Type	Power Factor per blade
In-skin Router Blade (CD-RTB)	2
In-skin UMS/Server Blade (CD-VM00)	2
In-skin HUB Blade (CD-ETIA)	2
Conference Bridge Blade (CD-PVAA) (for US/Australia)	1
Application Blade (CD-SVRU) (for US)	2

Table 4-4 Terminal Power Factor

Terminal Power Factor (Total has to be "80" or less in each 2U Chassis)		
	Terminal Type	Power Factor per Terminal
SLT	Standard (-28V)	0.8
	Long Line (-48V)	2
DT300 series	DT310 (2/6-button)	0.8
	DT330 (12/24/32-button)	0.8
	DT330 (Desi-less)	0.8
	DT330 (12-button) w/ PSA	2
	DT330 (12-button) w/ BCH	3
DT300 Option	DSS Console	2
	Analog Power Failure Adapter (PSA)	1.2
	Analog Port Adapter w/ Ringer (APR)	2
	Ancillary Device Adapter (ADA)	2
	Bluetooth HUB Adapter (BHA)	2
	Line Key Unit (8/16-button)	0
Desk Console (w/ AC Adapter)		0
DT700 series (PoE from CD-ETIA)	DT710 (2/6-button)	4
	DT730 (12/24/32-button)	4
	DT730 (Desi-less)	4
	DT730 (12-button) w/ PSA	4

(to be continued in next page)

Table 4-4 Terminal Power Factor (cont'd)

Terminal Power Factor (Total has to be "80" or less in each 2U Chassis)		
Terminal Type		Power Factor per Terminal
DT700 Option (PoE from CD-ETIA)	DT750 (32-button)	6
	Ancillary Device Adapter (ADA)	2
D ^{term} series i	2/4/8/16/32-button	0.8
D ^{term} series i Option	DSS Console	1
	Analog Port Adapter w/o Ringer (APA)	1
	Analog Port Adapter w/ Ringer (APR)	3
	Ancillary Device Adapter (ADA)	1
ZT		4.5
Paging Adapter		2

2. VoIP daughter board (VoIPDB)

There are two types of VoIPDBs, PZ-64IPLA and PZ-128IPLA. To select either PZ-64IPLA or PZ-128IPLA, a detailed traffic calculation is necessary.

The following table shows the VoIPDB channels required in each call connection.

Table 4-5 VoIPDB Channels Required in Each Call Connection

U01=UNIT01, UN=UNIT N, UM=UNIT M

From \ To		UNIT01					UNIT N (N=2-50)			
		TDM Line	D ^{term} IP	DT700 series	Std SIP Terminal	SIP Trunk	P2P CCIS	TDM Line	D ^{term} IP	DT700 series
UNIT01	TDM Line	U01: None	U01: 1ch	U01: 1ch	U01: 1ch	U01: 1ch	U01: 1ch	U01: 1ch UN: 1ch	U01: 1ch UN: None	U01: 1ch UN: None
	D ^{term} IP	U01: 1ch	U01: None	U01: None	U01: 2ch	U01: 2ch	U01: None	U01: None UN: 1ch	U01: None UN: None	U01: None UN: None
	DT700 series	U01: 1ch	U01: None*	U01: None	U01: 2ch	U01: 2ch	U01: None*	U01: None UN: 1ch	U01: None* UN: None*	U01: None UN: None
	Std SIP Terminal	U01: 1ch	U01: 2ch	U01: 2ch	U01: 0ch/2ch***	U01: 2ch	U01: 2ch	U01: 2ch UN: 1ch	U01: 2ch UN: None	U01: 2ch UN: None
	SIP Trunk	U01: 1ch	U01: 2ch	U01: 2ch	U01: 2ch	U01: 2ch	U01: 2ch	U01: 2ch UN: 1ch	U01: 2ch UN: None	U01: 2ch UN: None
	P2P CCIS	U01: 1ch	U01: None	U01: None	U01: 2ch	U01: 2ch	U01: None	U01: 2ch UN: 1ch	U01: None UN: None	U01: None UN: None
UNIT N (N=2-50)	TDM Line	U01: 1ch UN: 1ch	U01: None UN: 1ch	U01: None UN: 1ch	U01: 2ch UN: 1ch	U01: 2ch UN: 1ch	U01: 2ch UN: 1ch	UN: None	UN: 1ch	UN: 1ch
	D ^{term} IP	U01: 1ch UN: None	U01: None UN: None	U01: None UN: None	U01: 2ch UN: None	U01: 2ch UN: None	U01: None UN: None	UN: 1ch	UN: None	UN: None
	DT700 series	U01: 1ch UN: None	U01: None* UN: None*	U01: None UN: None	U01: 2ch UN: None	U01: 2ch UN: None	U01: None* UN: None*	UN: 1ch	UN: None*	UN: None

From \ To		UNIT M** (M=2-50)		
		TDM Line	D ^{term} IP	DT700 series
UNIT N** (N=2-50)	TDM Line	UM: 1ch UN: 1ch	UM: None UN: 1ch	UM: None UN: 1ch
	D ^{term} IP	UM: 1ch UN: None	UM: None UN: None	UM: None UN: None
	DT700 series	UM: 1ch UN: None	UM: None* UN: None*	UM: None UN: None

* One channel is assigned for sending DTMF signal in each connection.

** UNIT N is not same as UNIT M.

*** Resource channel is different according to the connection.

Call via VoIPDB : 2ch

Call via Peer-to-Peer connection: 0ch

To simplify the selection of the VoIPDBs, the following calculation method is recommended.

Table 4-6 Calculation Method of VoIPDB (Recommended)

	Standalone		Remote UNIT Network	
	324 ports or less (1-UNIT)	More than 324 ports (2-UNIT or more)	Main site	Remote site
TDM System	---	PZ-128IPLA x 1 per UNIT	PZ-128IPLA x 1 per UNIT	PZ-64IPLA x 1
IP (+ TDM) System	PZ-64IPLA x 1			

3. SIP Converter

When Standard SIP Terminals are accommodated in SV8300, SIP Converters should be assigned in UNIT01. One SIP Converter has three channels, maximum 32 SIP Converters can be assigned.

The following table shows the SIP Converter channels required in each call connection.

Table 4-7 SIP Converter Channels Required in Each Call Connection

From \ To		UNIT01						UNIT N (N=2-50)		
		TDM Line	D ^{term} IP	DT700 series	Std SIP Terminal	SIP Trunk	P2P CCIS	TDM Line	D ^{term} IP	DT700 series
UNIT01	TDM Line	None	None	None	1ch	None	None	None	None	None
	D ^{term} IP	None	None	None	1ch	None	None	None	None	None
	DT700 series	None	None	None	1ch	None	None	None	None	None
	Std SIP Terminal	1ch	1ch	1ch	2ch	1ch	1ch	1ch	1ch	1ch
	SIP Trunk	None	None	None	1ch	None	None	None	None	None
	P2P CCIS	None	None	None	1ch	None	None	None	None	None
UNIT N (N=2-50)	TDM Line	None	None	None	1ch	None	None	None	None	None
	D ^{term} IP	None	None	None	1ch	None	None	None	None	None
	DT700 series	None	None	None	1ch	None	None	None	None	None

4. Limitation of Mounting Location

- CD-2BRIA /CD-PRTA

- ✓ When CD-2BRIA (BRT) / CD-PRTA (PRT/QSIG/DTI) blades are mounted in a main site or a standalone system, at least one of the blades has to be mounted in UNIT01 and the remaining blades can be mounted in any UNITS. However, if CS Interface (CSI) blades are distributed to multiple UNITS, all the CD-2BRIA/CD-PRTA blades have to be mounted in UNIT01.
- ✓ When unrestricted digital channels are required (e.g. G4 FAX), there are limitations as follows.
 - **For u-law systems (US and Hong Kong)**

The CD-2BRIA (ILC/BRT) / CD-PRTA (PRT) blades can be mounted in any UNIT. However,

 1. 16 Time Slots are available for the unrestricted digital channels in each 2U Chassis. (The Time Slots available for the unrestricted digital channels can be flexibly assigned in the 2U Chassis.)
 2. Data communication using the unrestricted digital channels is available within each UNIT. (Inter-UNIT connection is not available.)
 - **For A-law systems**

The CD-2BRIA (ILC/BRT) / CD-PRTA (PRT) blades can be mounted in any UNIT. However, data communication using the unrestricted digital channels is available within each UNIT. (Inter-UNIT connection is not available.)

- CD-CCTA (CCT)

When CD-CCTA blades are mounted in a main site or a standalone system, at least one of the blades has to be mounted in UNIT01 and the remaining blades can be mounted in any UNITS. However, if CS Interface (CSI) blades are distributed to multiple UNITS, all the CD-CCTA blades have to be mounted in UNIT01.

- CD-8DLCA / CD-16DLCA (DLC)

When Desk Consoles are accommodated in the SV8300, the CD-8DLCA / CD-16DLCA blades for the Desk Consoles have to be mounted in the UNIT01. (There are other limitations for the Desk Console accommodation. Please refer to Chapter 6.5 for more detail.)

5. Installation Type

To meet the specific needs of the customer's environment, SV8300 provides the various installation methods as follows:

- Floor Mounting Installation
- Wall Mounting Installation
- 19 inch Rack Mounting Installation
- Desktop Mounting Installation
- Floor Mounting / Desk Mounting Installation with Stand

Note: Condition of Secondary UNIT for Failover mode

When floor mounting (w/o stand) / 19-inch rack mounting / desktop mounting, Secondary UNIT (1U Chassis) can be installed on the top of another UNIT.

When external batteries are required, Secondary UNIT (1U Chassis) can not be installed on the top of another UNIT. The external batteries must be installed in close proximity of the UNITS.

5.1 Floor Mounting Installation

All UNITS at Main Site (UNIT 01-04) have to be installed at the same location.

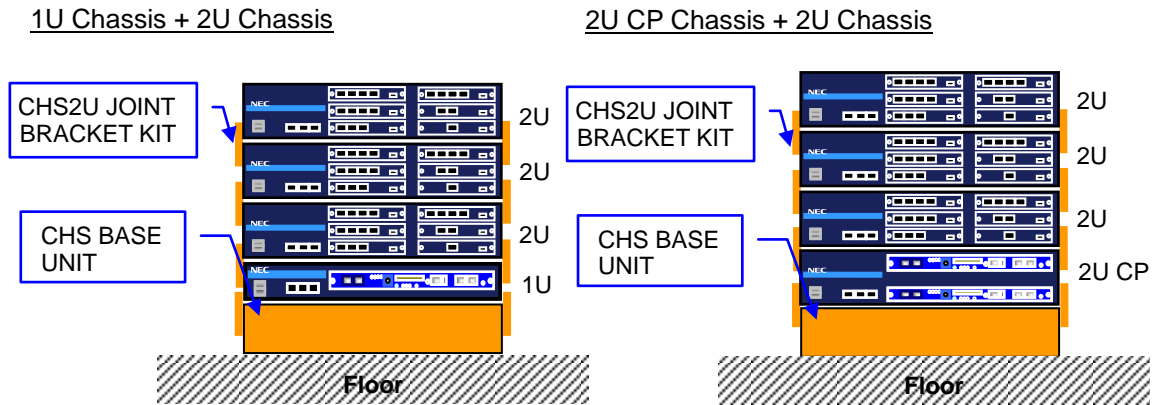

Figure 5-1 Floor Mounting Installation

Table 5-1 Hardware for Floor Mounting Installation

Description	B Code	Feature	SV 8300	SV 8100
CHS BASE UNIT	BE106406	Floor Mount Bracket	X	X
CHS2U JOINT BRACKET KIT	BE106414	Upper Joint Bracket Kit (2 x Joint Bracket)	X	X

5.2 Wall Mounting Installation

SV8300 can be mounted on the wall as shown below.

1U Chassis + 2U Chassis

Maximum of one 1U Chassis and one 2U Chassis can be mounted on the wall.

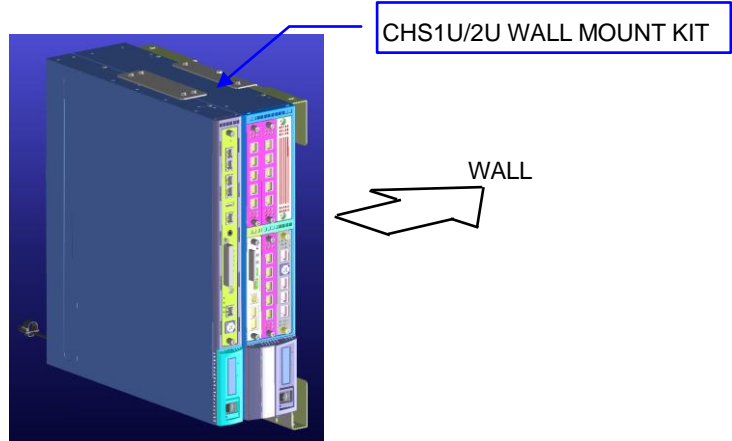

2U CP Chassis + 2U Chassis

Maximum one 2U CP Chassis and one 2U Chassis can be mounted on the wall, however, they have to be mounted respectively.

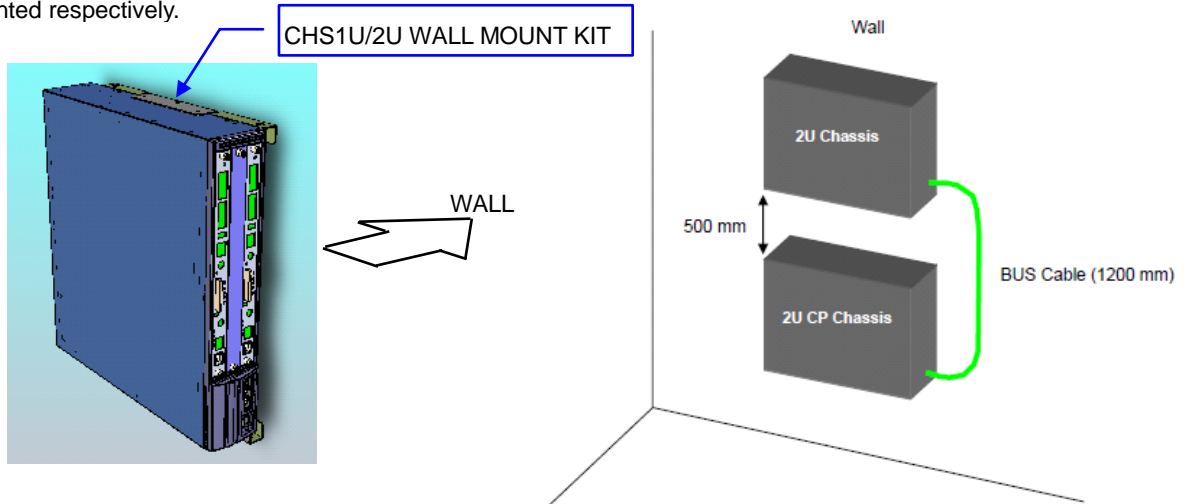

Figure 5-2 Wall Mounting Installation

Table 5-2 Hardware for Wall Mounting Installation

Description	B Code	Feature	SV 8300	SV 8100
CHS1U/2U WALL MOUNT KIT	BE106407	Wall Mount Kit (2 x Joint Bracket included)	X	X

5.3 19 inch Rack Mounting Installation

SV8300 can be mounted in the IEC-standard 19 inch rack.
 (IEC: International Electrotechnical Commission)

All UNITS at Main Site (UNIT 01-04) have to be installed at the same location.
 All Chassis of configured UNIT have to be installed in series without any vacant space.

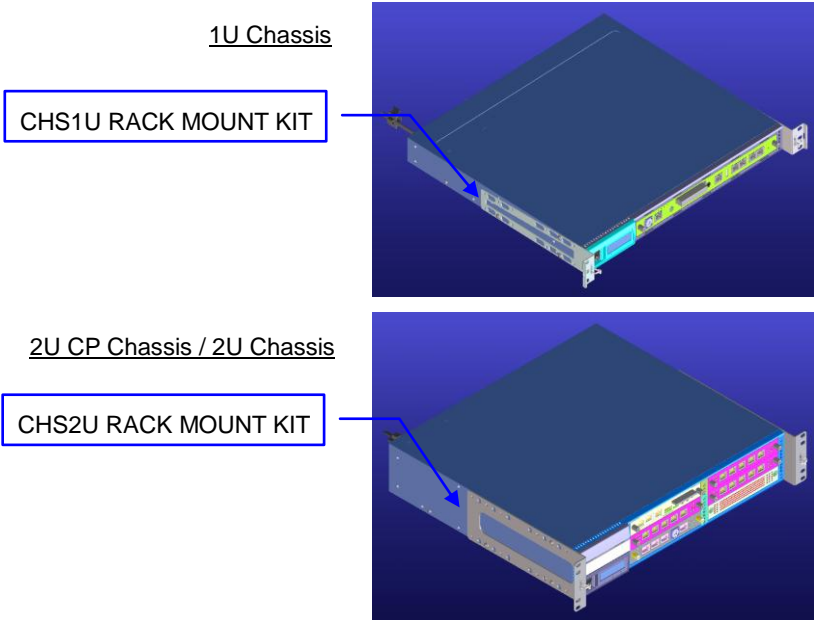

Figure 5-3 19 inch Rack Mounting Installation

Table 5-3 Hardware for 19 inch Rack Mounting Installation

Description	B Code	Feature	SV 8300	SV 8100
CHS1U RACK MOUNT KIT	BE106399	19 inch Rack Mount Kit for 1U Chassis	X	-
CHS2U RACK MOUNT KIT	BE106405	19 inch Rack Mount Kit for 2U CP Chassis / 2U Chassis	X	X

5.4 Desktop Mounting Installation

All UNITS at Main Site (UNIT 01-04) have to be installed at the same location.

1U Chassis + 2U Chassis

2U CP Chassis + 2U Chassis

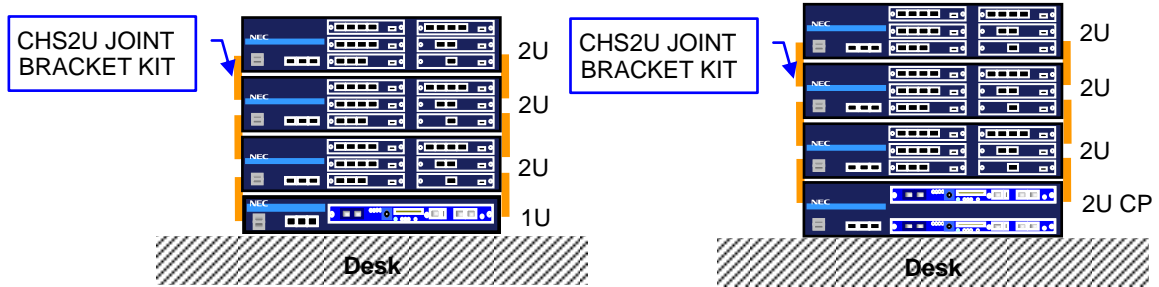

Figure 5-4 Desktop Mounting Installation

Table 5-4 Hardware for Desktop Mounting Installation

Description	B Code	Feature	SV 8300	SV 8100
CHS2U JOINT BRACKET KIT	BE106414	Upper Joint Bracket Kit (2 x Joint Bracket)	X	X

5.5 Floor Mounting / Desktop Mounting Installation with Stand

SV8300 can be installed on a floor / desk with vertical stand.
 All UNITS at Main Site (UNIT 01-04) have to be installed at the same location.

1U Chassis + 2U Chassis

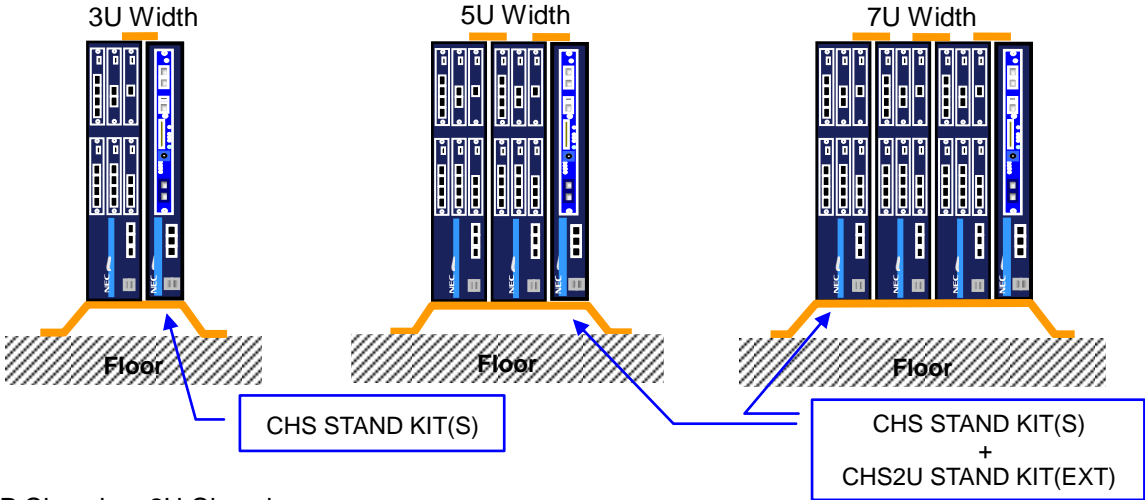

2U CP Chassis + 2U Chassis

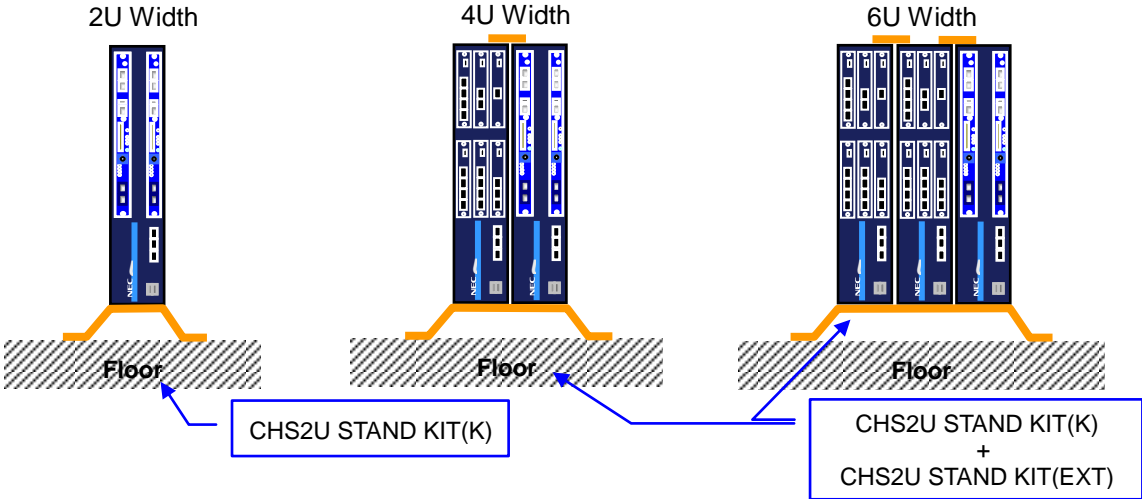

Figure 5-5 Floor Mounting / Desktop Mounting Installation with Stand

Note 1: CHS STAND KIT(S) is available for 3U width (1U Chassis + 2U Chassis).

To expand to 5U or 7U width, CHS2U STAND KIT(EXT) is additionally required.

The CHS2U STAND KIT(EXT) consists of 2U expansion plate x 2 and joint bracket x 2.

- 5U width (1U Chassis + 2U Chassis x 2): 2U expansion plate x 1 and Joint Bracket x 1 used
- 7U width (1U Chassis + 2U Chassis x 3): 2U expansion plate x 2 and Joint Bracket x 2 used

Note 2: CHS2U STAND KIT(K) is available for 2U width (2U CP Chassis).

To expand to 4U or 6U width, CHS2U STAND KIT(EXT) is additionally required.

The CHS2U STAND KIT(EXT) consists of 2U expansion plate x 2 and joint bracket x 2.

- 4U width (2U CP Chassis + 2U Chassis x 1): 2U expansion plate x 1 and Joint Bracket x 1 used
- 6U width (2U CP Chassis + 2U Chassis x 2): 2U expansion plate x 2 and Joint Bracket x 2 used

Table 5-5 Hardware for Floor Mounting / Desktop Mounting Installation with Stand

Description	B Code	Feature	SV 8300	SV 8100
CHS STAND KIT(S)	BE106408	Vertical Stand Kit (3U width) (1 x Joint Bracket included)	X	-
CHS2U STAND KIT(K)	BE106910	Vertical Stand Kit (2U width)	X	X
CHS2U STAND KIT(EXT)	BE106727	Expansion Plates Kit for Vertical Stand (2 x 2U expansion plate and 2 x Joint Bracket included)	X	X

6. Cabling

The following figures show internal / external cabling of the SV8300.

6.1 Inter-Chassis Connection

Inter-Chassis Connection inside of a UNIT is made with BUS Cables as shown below. The BUS Cable is attached in BUS Interface Blade for 2U Chassis (PZ-BS11).

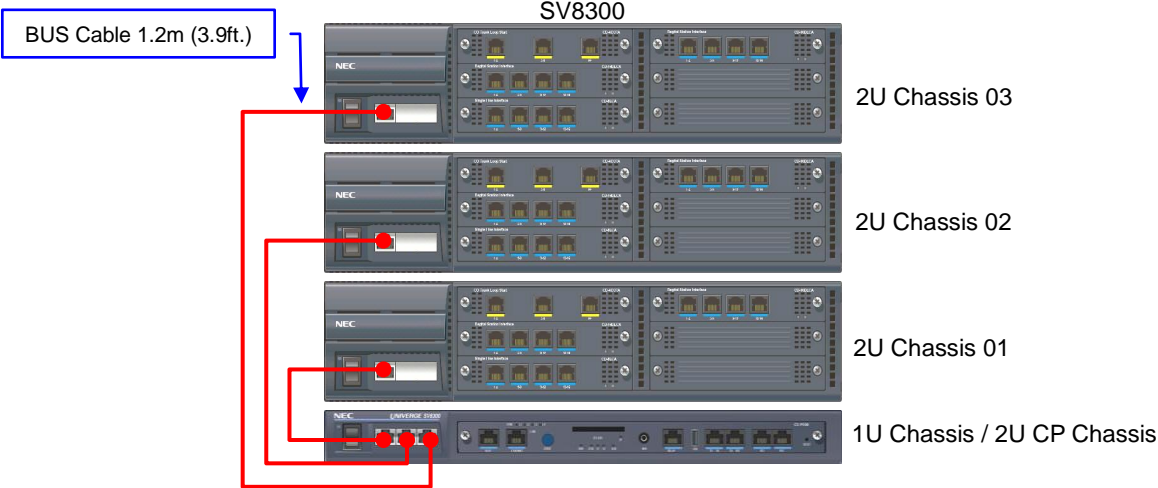

Figure 6-1 Inter-Chassis Connection

Inter-UNIT connection inside of main site or standalone system is made with LAN Cable, same manner of Remote UNIT over IP. Please refer to “IP Connection” in this chapter.

6.2 CSI Synchronization Cable Connection

When CS Interface (CSI) blades are distributed to multiple UNITS at the main site or a standalone system, all of the UNITS have to be connected UNIT by UNIT with CSI Synchronization Cable. When CSI blades are mounted in a single UNIT at the main site or a standalone system, this connection is not necessary.

The connection is required in addition to Inter-UNIT connection described in “IP Connection”.

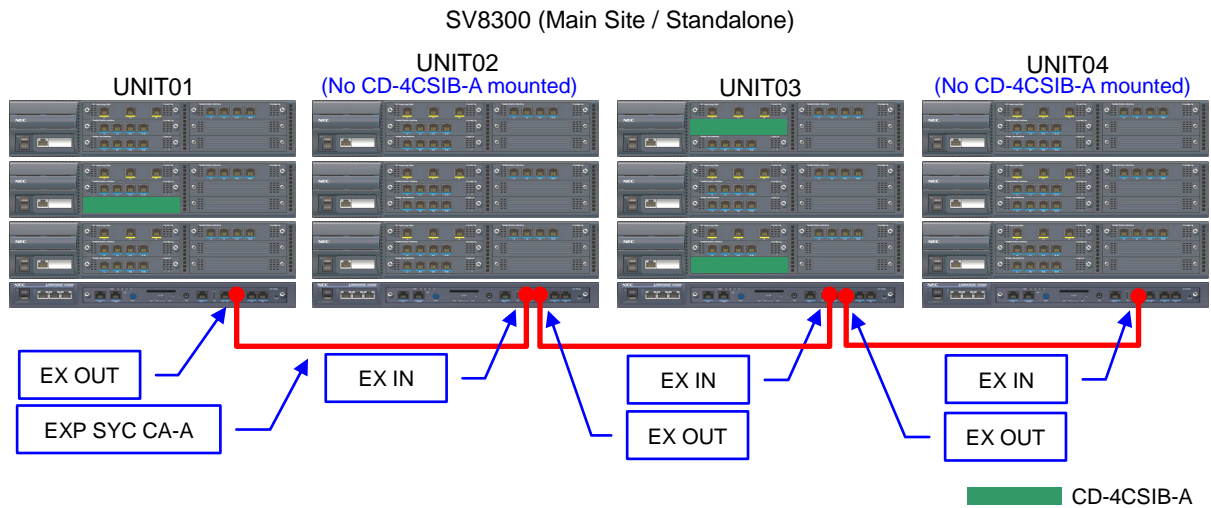

Figure 6-2 CSI Synchronization Cable Connection

Note: On Dual CPU configuration, EX OUT / EX IN port on either #0 CPU or #1 CPU in UNIT01 can be used.

Table 6-1 CSI Synchronization Cable

Description	B Code	Feature	SV 8300	SV 8100
EXP SYNC-3 CA-A	BE107106	CSI Synchronization Cable, 3.0m (9.8ft)	X	-

6.3 AC Cord Connection

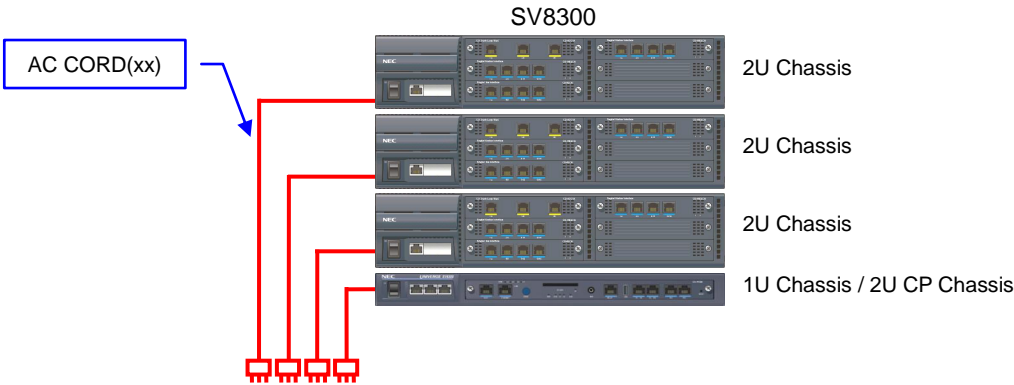

Figure 6-3 AC Cord Connection

Table 6-2 AC Cord

Description	B Code	Feature	SV 8300	SV 8100
AC CORD(UJ)	BE106731	AC Power Cable (for US)	X	X
AC CORD(AU)	BE106732	AC Power Cable (for Australia)	X	X
AC CORD(EU)	BE106733	AC Power Cable (for EU / Asia / Russia)	X	X
AC CORD-B(CH)	---	AC Power Cable (for China)	X	X

6.4 Battery Cable Connection

(1) Built-in Battery Cable Connection

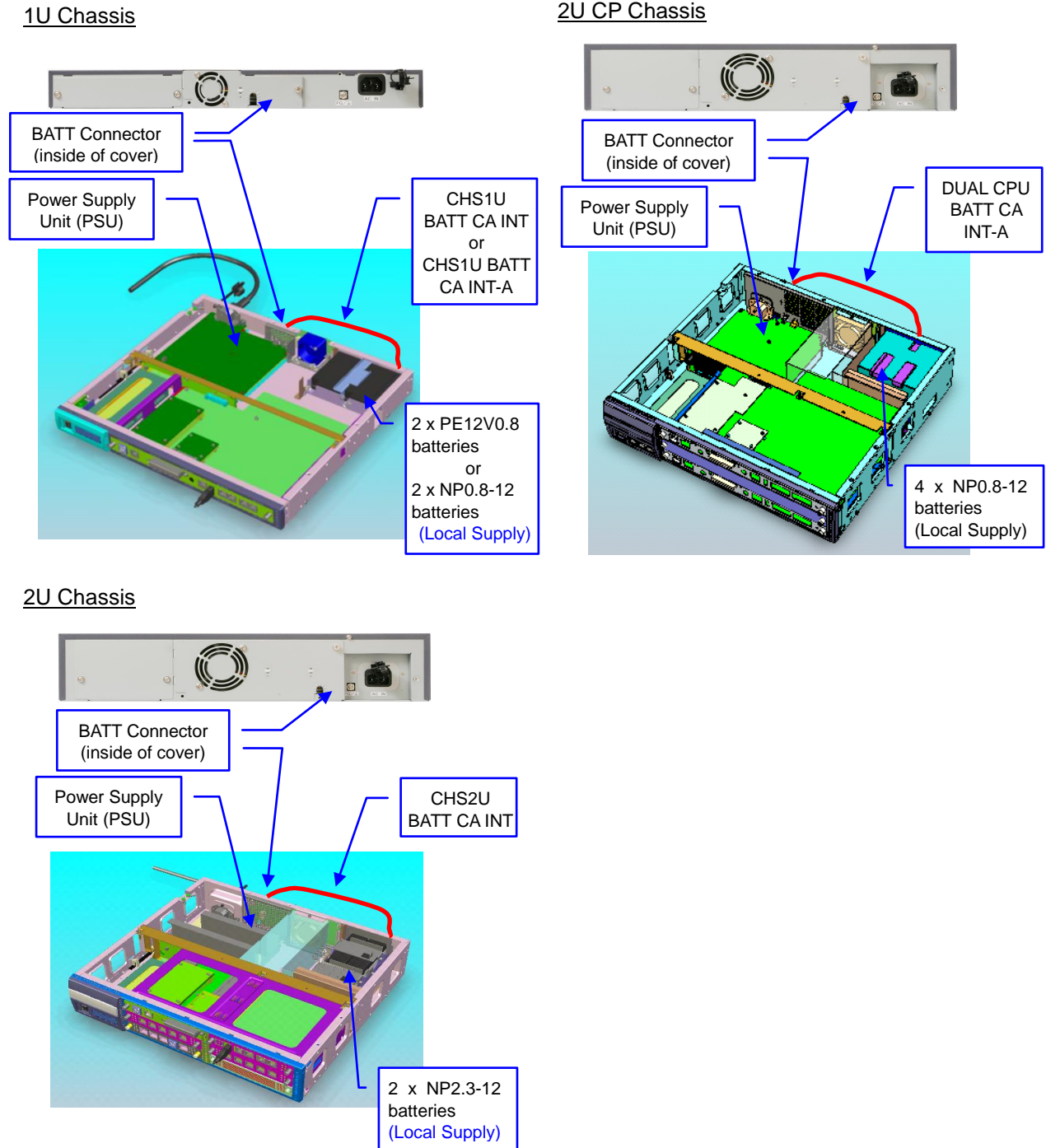

Figure 6-4 Built-in Battery Connection

Table 6-3 Built-in Battery Cable

Description	B Code	Feature	SV 8300	SV 8100
CHS1U BATT CA INT	BE106736	Battery Cable for short-term built-in batteries (with Tyco. 1-480318-0 connectors) for 1U Chassis Including; <ul style="list-style-type: none"> ● 1 x Cable (270mm (0.9ft)) Cable from 1U Chassis to batteries 	X	-
CHS1U BATT CA INT KIT(GS-NP)	BE107370	Battery Cable for short-term built-in batteries (with JST SVH-21T-P1.1 connectors) for 1U Chassis (for EU / Australia etc.) Including; <ul style="list-style-type: none"> ● 1 x Cable (270mm (0.9ft)) Cable from 1U Chassis to batteries ● 1 x PZ-M710 JST connectors board ● Accessories for PZ-M710 mounting 	X	-
DUAL CPU BATT CA INT-A	---	Battery Cable for short-term built-in batteries for 2U CP Chassis. Included in CHS2U(D) BATT MTG KIT. Please refer to Table 3-4.	X	-
CHS2U BATT CA INT	BE106737	Battery Cable for short-term built-in battery for 2U Chassis Including; <ul style="list-style-type: none"> ● 1 x Cable A (480mm (1.6ft)) Cable from 2U Chassis to batteries (JST Faston tab 187 connectors) ● 1 x Cable B (80mm (0.3ft)) Cable between batteries (JST Faston tab 187 connectors) 	X	X

(2) External Battery Cable Connection w/ Battery Box

When CHS LARGE BATT BOX is used, there are two types of the external battery cable. Connections are shown below.

The battery cables are attached in the CHS LARGE BATT BOX.

Only Floor Mounting Installation is available.

The external batteries must be installed in close proximity of the UNITS.

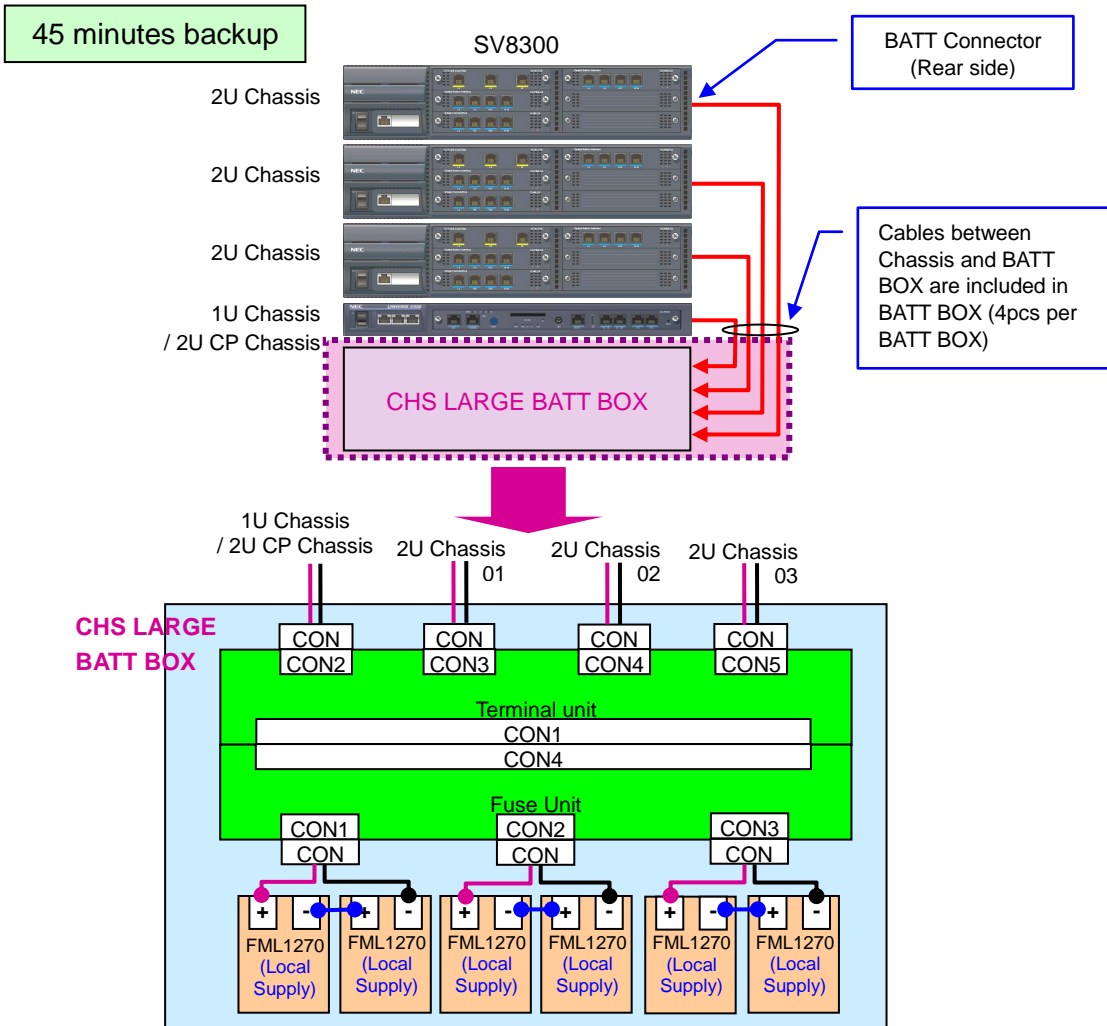

Figure 6-5 External Battery Connection (45 minutes backup)

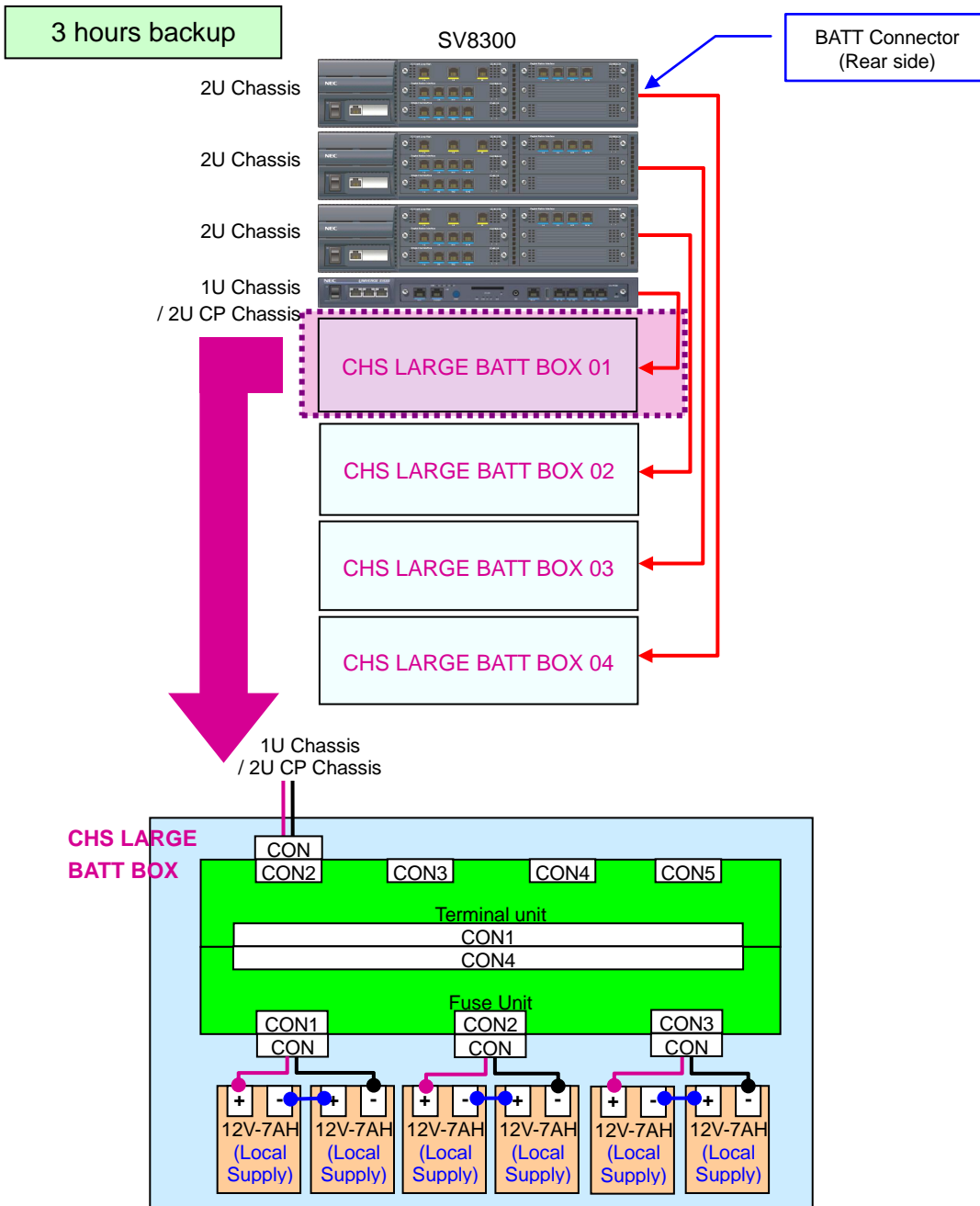

Figure 6-6 External Battery Connection (3 hours backup)

(3) External Battery Cable Connection w/o Battery Box

When external batteries are required, the external batteries must be installed in close proximity of the UNITS.

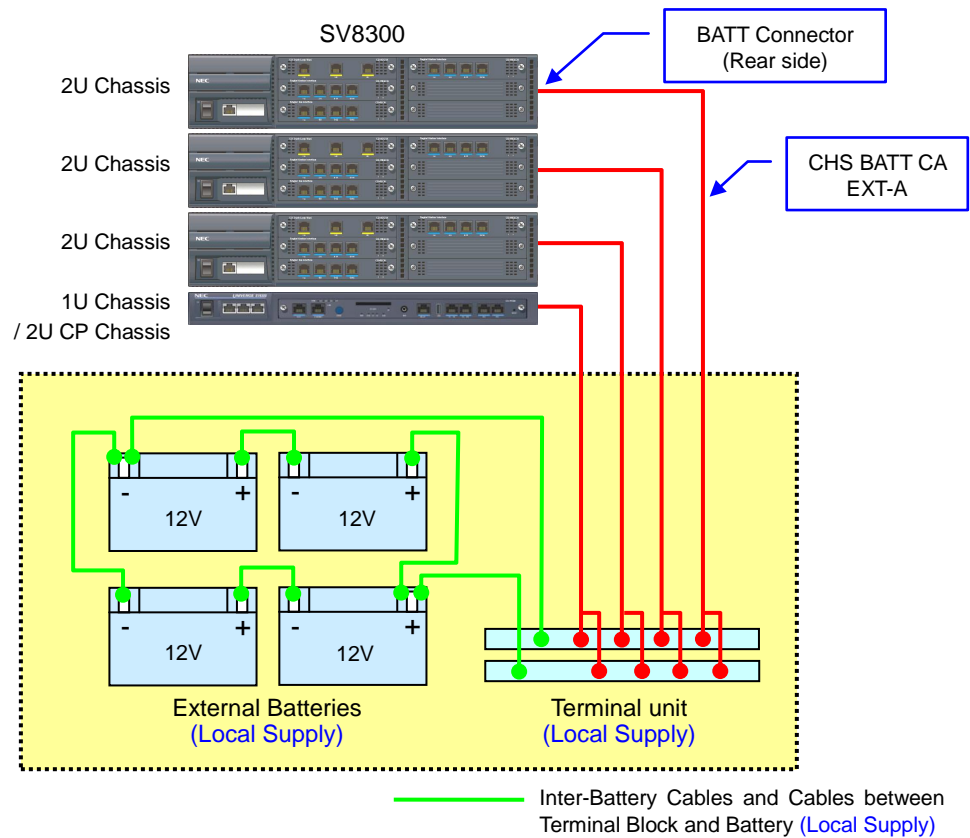

Figure 6-7 External Battery Connection w/o Battery Box

Table 6-4 External Battery Cable w/o Battery Box

Description	B Code	Feature	SV 8300	SV 8100
CHS BATT CA EXT-A	BE106738	External Battery Cable (1 per Chassis) Including <ul style="list-style-type: none"> 1 x Cable (400mm (1.3ft)) Chassis – Terminal Unit 	X	X

Table 6-5 Battery Capacity of External Battery w/o Battery Box

Configuration	Battery Capacity (Number of Batteries)	Number of CHS BATT CA EXT-A
1U/2U CP	24AH (12V-24AH x 2 pcs)	1
1U/2U CP + 2U		2
1U/2U CP + 2Ux2	48AH (12V-24AH x 4 pcs)	3
1U/2U CP + 2Ux3		4

6.5 Desk Console Connection

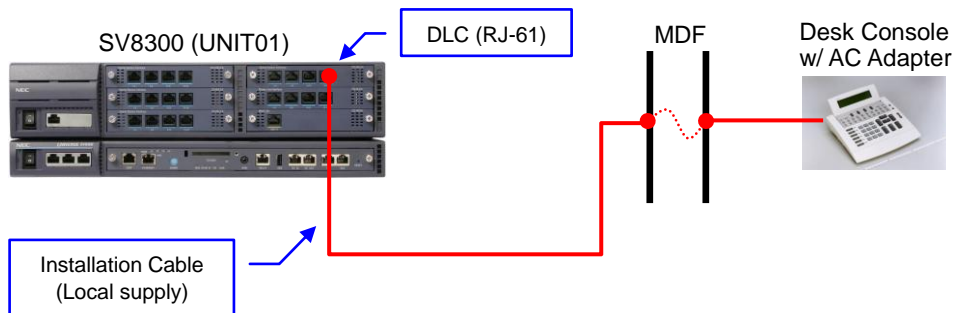

Figure 6-8 Desk Console Connection

Note: Desk Consoles can be accommodated in the SV8300 with the following limitations.

- 1) The following models of the Desk Consoles can be accommodated.
 - SN716 DESK CON A-C
 - SN753 DESK CON F-A (for EU)
- 2) The DLC blade and the Desk Console have to be updated to the following firmware (F/W) versions.
 - DLC Blade F/W: ver. 2.3 or higher
 - SN716 DESK CON A-C F/W: ver. 7A or higher
 - SN753 DESK CON F-A F/W: ver. 7A or higher
- 3) The DLC blades for the Desk Consoles have to be mounted in the UNIT01.
- 4) Maximum 2 x Desk Consoles can be accommodated in a DLC blade.
DT300, D^{term}IP (series-E/i) and DSS Console can be accommodated in the DLC blade together.
- 5) Maximum 8 x Desk Consoles can be accommodated in a system.
- 6) AC Adapters are mandatory required for the Desk Consoles.

6.6 PCPro Connection

(1) PCPro Direct Connection

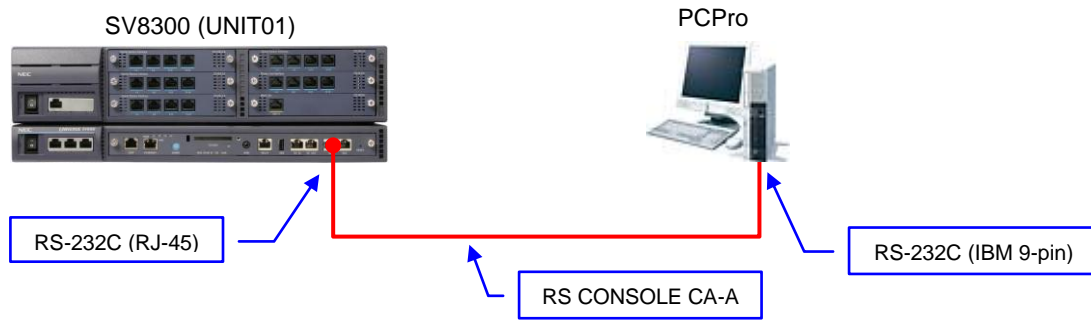

Figure 6-9 PCPro Direct Connection

Note 1: RS-232C ports in UNIT01 are available for PCPro connection during the normal operation.
 Note 2: On Dual CPU configuration, RS-232C ports on either #0 CPU or #1 CPU in UNIT01 can be used.

Table 6-6 PCPro Connection Cable

Description	B Code	Feature	SV 8300	SV 8100
RS CONSOLE CA-A	BE106426	PCPro Connection Cable 2.0m (6.6ft)	X	-

(2) PCPro Remote Connection (via internal modem of VMDB)

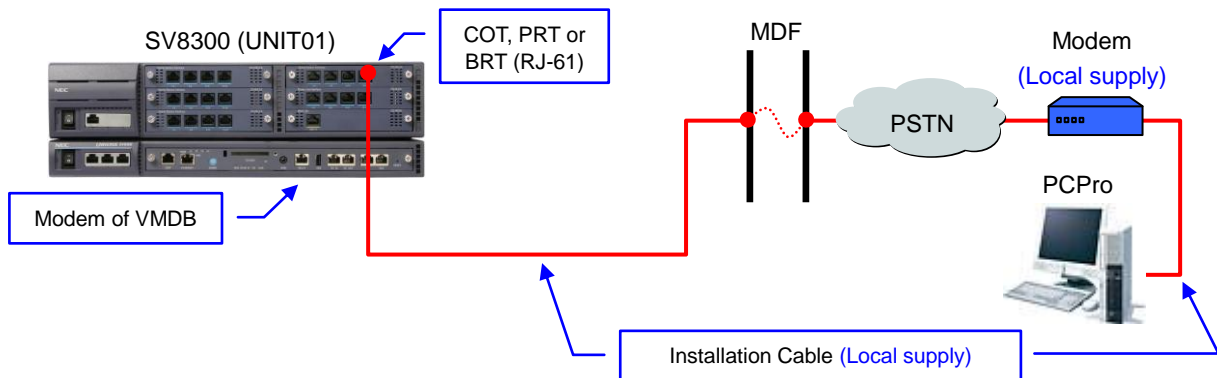

Figure 6-10 PCPro Remote Connection (via internal modem of VMDB)

Note: Internal modem and COT/PRT/BRT in UNIT01 is available for the PCPro remote connection.

(3) PCPro Remote Connection (via external modem)

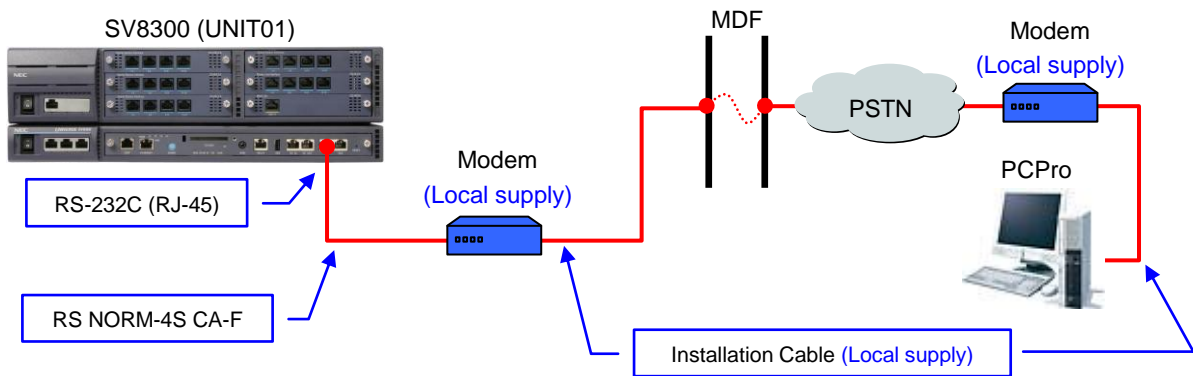

Figure 6-11 PCPro Remote Connection (via external modem)

Note 1: RS-232C ports in UNIT01 are available for PCPro connection during the normal operation.

Note 2: Connection from PCPro is only available.

Note 3: On Dual CPU configuration, RS-232C ports on either #0 CPU or #1 CPU in UNIT01 can be used.

Table 6-7 PCPro Remote Connection Cable (via external modem)

Description	B Code	Feature	SV 8300	SV 8100
RS NORM-4S CA-F	BE106427	RS-232C Cable (normal) 4.0m (13.1ft) (inch screw, MALE)	X	-

6.7 SMDR / Hotel Printer / MCI / PMS Connection

(1) SMDR / Hotel Printer / MCI / PMS Direct Connection (via RS-232C)

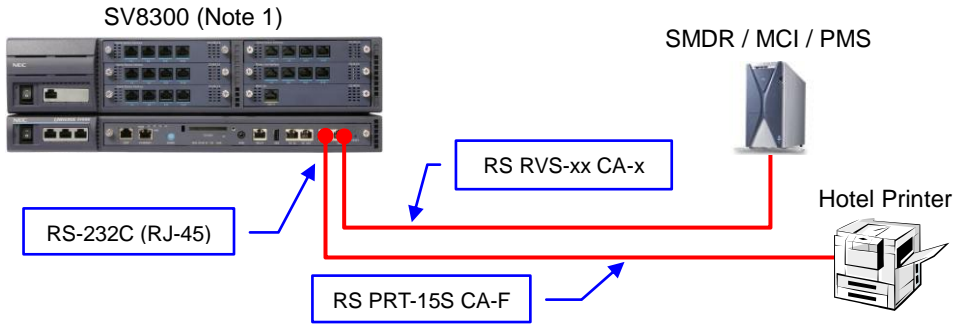

Figure 6-12 SMDR / Hotel Printer / MCI / PMS Direct Connection

Note 1: RS-232C ports in UNIT01 are available for PCPro, SMDR, Hotel Printer, MCI and PMS connections. On the other hand, RS-232C ports in UNIT02 and UNIT03 are available for Hotel Printer, MCI and PMS connections.

Note 2: On Dual CPU configuration, RS-232C ports on either #0 CPU or #1 CPU in UNIT01 can be used.

Table 6-8 SMDR / Hotel Printer / MCI Direct Connection Cable

Description	B Code	Feature	SV 8300	SV 8100
RS RVS-15S CA-F	BE106428	RS-232C Cable (reverse) 15.0m (49.2ft) (inch screw, MALE)	X	-
RS RVS-4S CA-F	BE106429	RS-232C Cable (reverse) 4.0m (13.1ft) (inch screw, MALE)	X	-
RS RVS-4S CA-G	BE106430	RS-232C Cable (reverse) 4.0m (13.1ft) (inch screw, FEMALE)	X	-
RS PRT-15S CA-F	BE106431	RS-232C Cable (Printer) 15.0m (49.2ft) (inch screw, MALE)	X	-

(2) SMDR / MCI / PMS Remote Connection (via external modem)

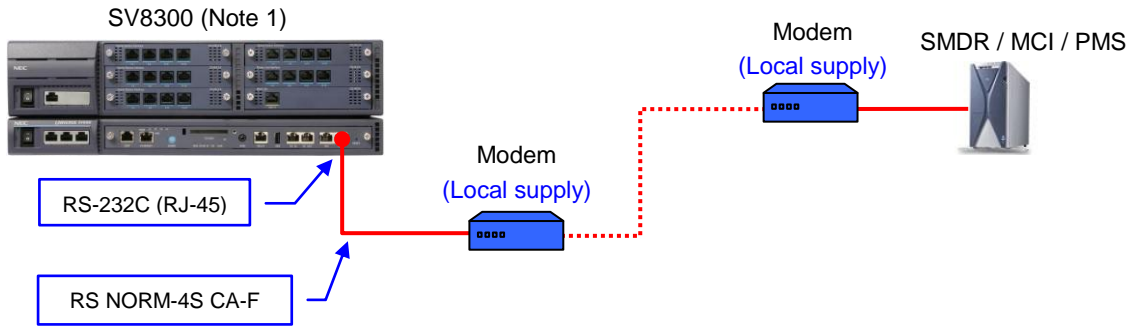

Figure 6-13 SMDR / MCI / PMS Remote Connection (via external modem)

Note 1: RS-232C ports in UNIT01 are available for PCPro, SMDR, Hotel Printer, MCI and PMS connections. On the other hand, RS-232C ports in UNIT02 and UNIT03 are available for Hotel Printer, MCI and PMS connections.

Note 2: On Dual CPU configuration, RS-232C ports on either #0 CPU or #1 CPU in UNIT01 can be used.

Table 6-9 SMDR / MCI Remote Connection Cable (via external modem)

Description	B Code	Feature	SV 8300	SV 8100
RS NORM-4S CA-F	BE106427	RS-232C Cable (normal) 4.0m (13.1ft) (inch screw, MALE)	X	-

6.8 Alarm Display Connection

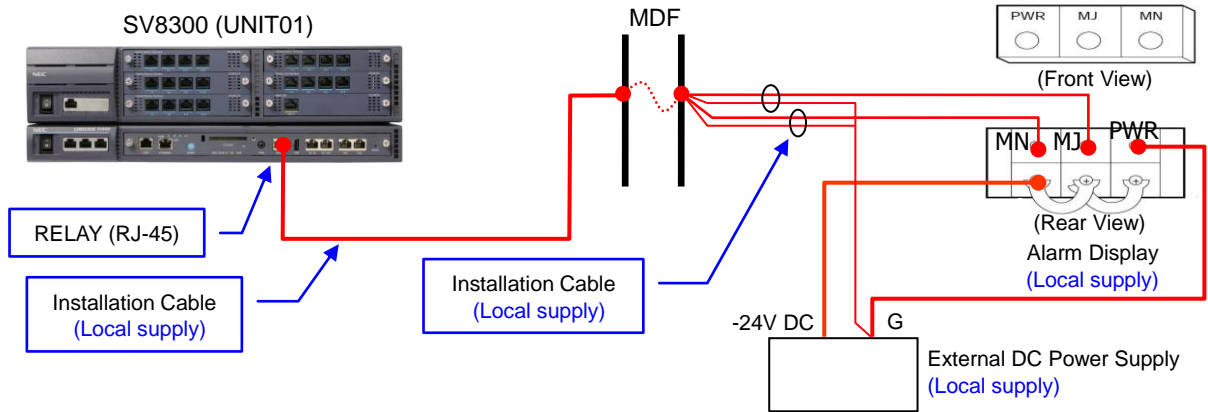

Figure 6-14 Alarm Display Connection

Note: On Dual CPU configuration, Relay port on either #0 CPU or #1 CPU in UNIT01 can be used.

6.9 TAS Equipment Connection

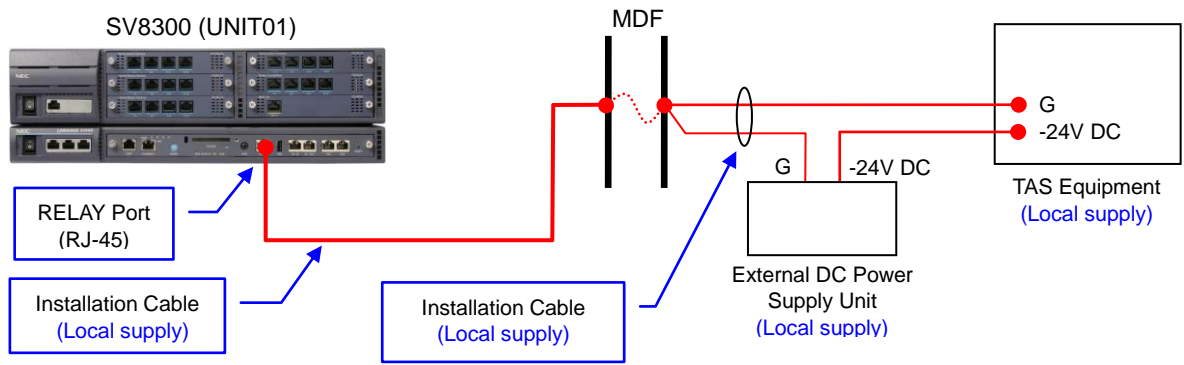

Figure 6-15 TAS Equipment Connection

Note: On Dual CPU configuration, Relay port on either #0 CPU or #1 CPU in UNIT01 can be used.

6.10 External Paging Connection

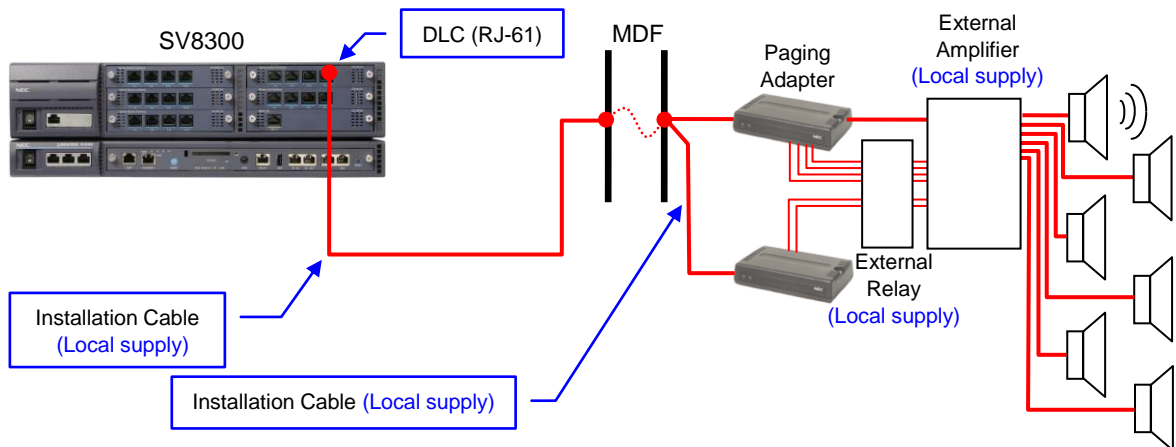

Figure 6-16 External Paging Connection

Note: Paging Adapter model is different in each market.

- PGD(2)-U10 ADP (for US)
- PGD(2)-U13 ADP (for Australia)
- IP1WW-2PGDAD (for EU / Asia / Russia / China)

6.11 External Music Source Connection

(1) External Music Source Connection – Built-in MoH Port

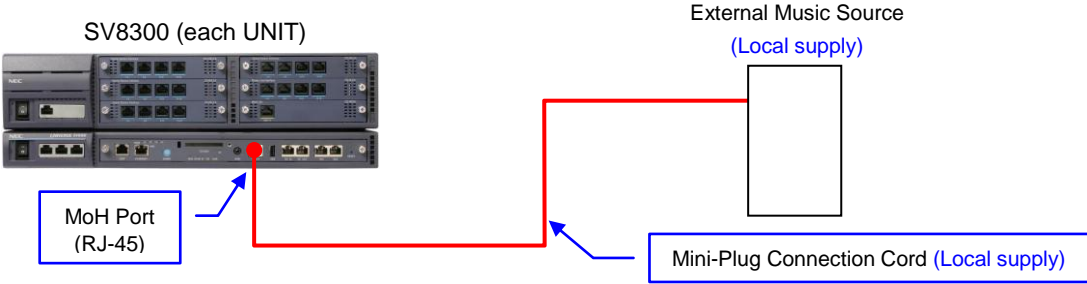

Figure 6-17 External Music Source Connection – Built-in MoH Port

Note: On Dual CPU configuration, the external music source needs to be connected to each MoH port on #0 CPU and #1 CPU in UNIT01.

(2) External Music Source Connection – Paging Adapter

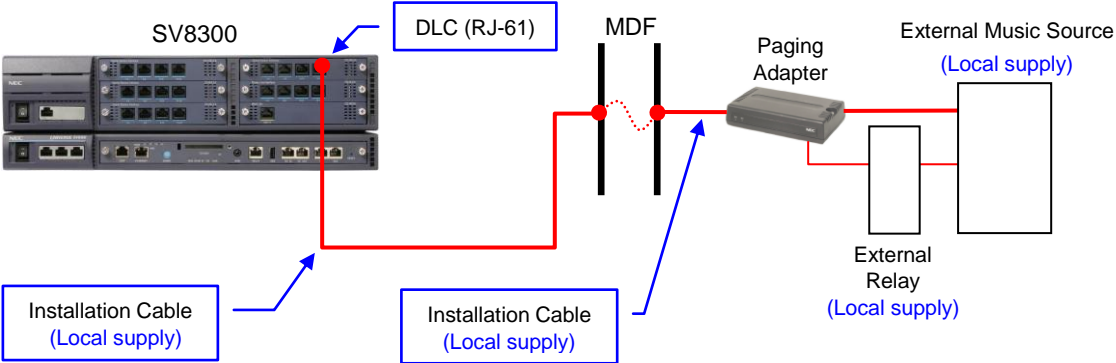

Figure 6-18 External Music Source Connection – Paging Adapter

Note: Paging Adapter model is different in each market.

- PGD(2)-U10 ADP (for US)
- PGD(2)-U13 ADP (for Australia)
- IP1WW-2PGDAD (for EU / Asia / Russia / China)

6.12 IP Connection

There are two types of NIC ports in a CPU blade.

One is VoIP Port on VoIPDB. It is Gigabit Ethernet port (10BASE-T/100BASE-TX/1000BASE-T), which is mainly used for IP terminals.

Another is Maintenance Port on the CPU blade. It is Fast Ethernet port (10BASE-T/100BASE-TX), which is mainly used for PCPro. Only Maintenance Port in UNIT01 is available during normal operation.

The availability of the NIC ports for each application is shown below.

Table 6-10 NIC Port Setting by Application

	Maintenance Port	VoIP Port	Remarks
IP Phone (DT700 series etc.)	NA	X	
P2P CCIS Trunk	NA	X	
SIP Trunk	NA	X	
PCPro	X	X	Can use both ports at the same time
OAI	X	X	Select the port
SMDR	X	X	Select the port
PMS	X	X	Select the port
SNMP	X	X	<ul style="list-style-type: none"> ● GET/SET commands from PC: Can use both ports at the same time ● TRAP command from PBX: Can use a port the default gateway is set
WLAN Controller / AP	NA	X	
Inter-UNIT connection	NA	X	
Remote-UNIT connection Note	NA	X	
Dual CPU Data Synchronization	X	NA	2U CP Chassis (UNIT01) only

X: Available, NA: Not available

Note: Including Secondary UNIT connection for Failover Mode

When both types of the NIC ports are used at the same time, the followings must be considered.

- The VoIP and Maintenance ports must be on a different subnet.
- Default gateway can be set to either the VoIP Port or the Maintenance Port, but not both.

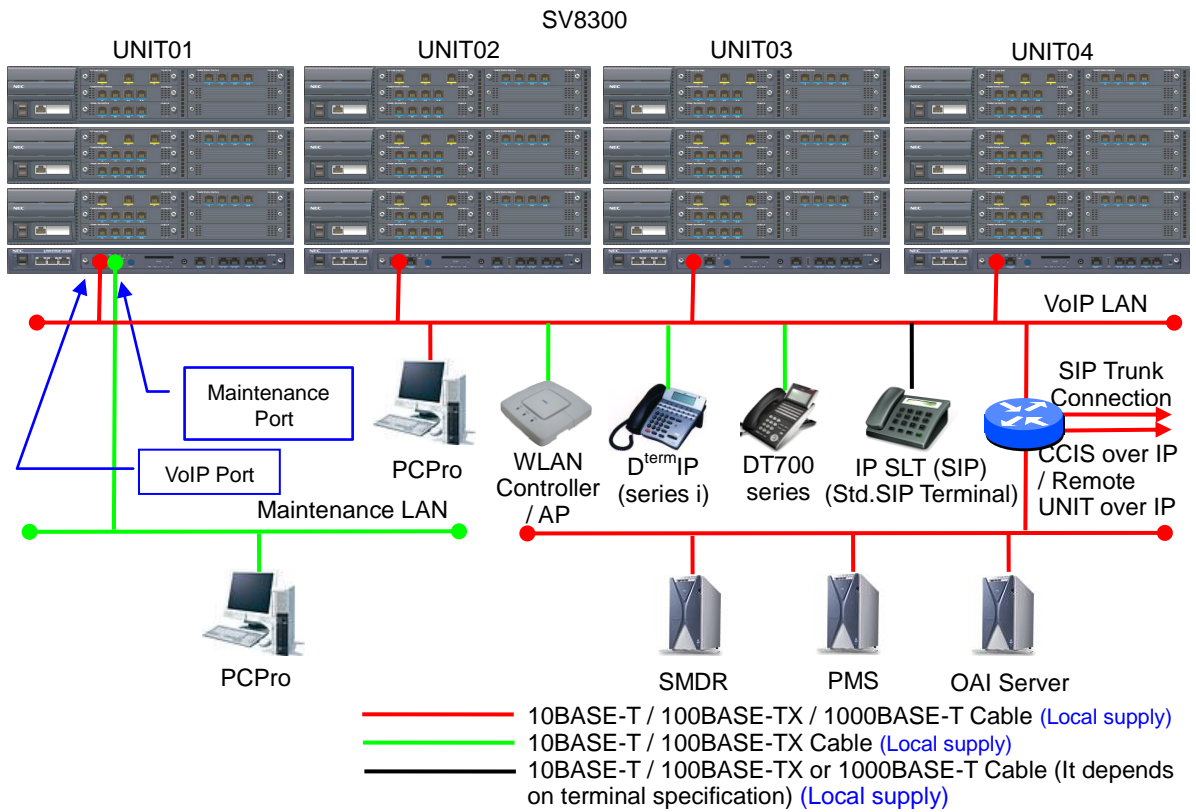

Figure 6-19 IP Connection (IP System or Multi-UNIT configuration)

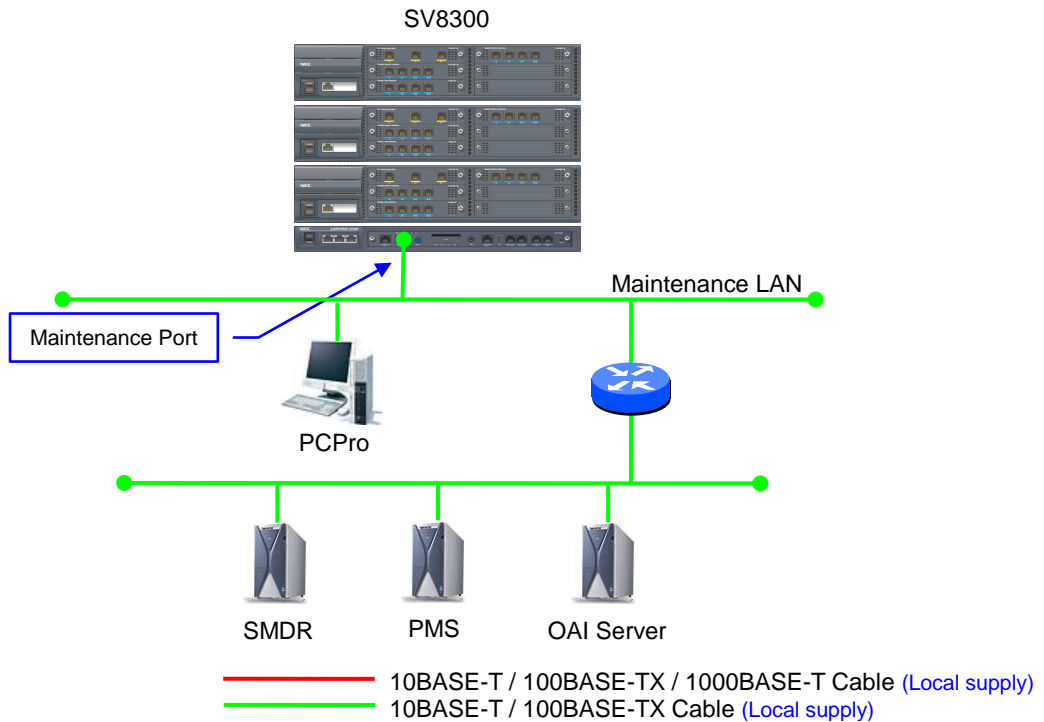

Figure 6-20 IP Connection (TDM System with 1-UNIT configuration)

On Dual CPU configuration, CPU blades mounted in 2U CP Chassis have to be connected to each other to synchronize the system data, charging data, license data etc. The following connection methods are available.

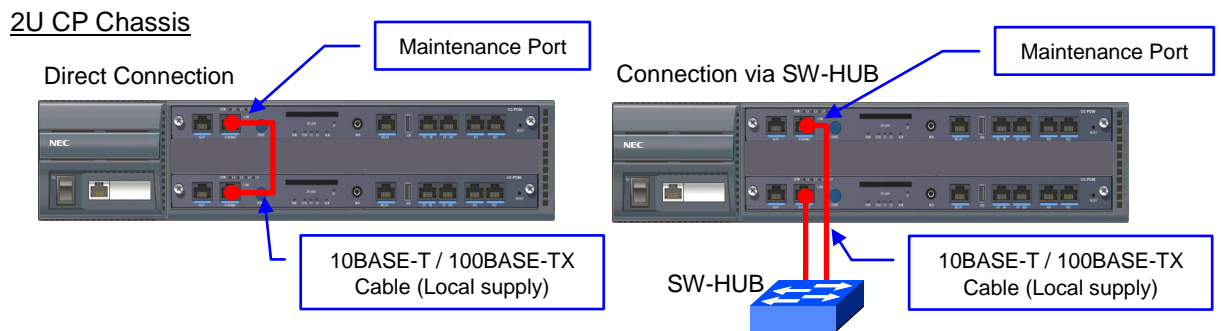

Figure 6-21 Internal Chassis Connection (2U CP Chassis)

A closed and bandwidth guaranteed network is preferable, such as IP-VPN (Layer 3 VPN) or Wide Area Ethernet service (Layer 2 VPN).

The following table shows the network requirement for the inter-UNIT connection and the Remote-UNIT connection.

Table 6-11 Network Requirement for inter-UNIT/Remote-UNIT connections

Item	Requirement		
	Inter-UNIT connection (between UNIT01 and UNIT02-04)	Remote-UNIT connection (Note) (between UNIT01 and UNIT05-50)	
Protocol	TCP/IP transparent		
Maximum delay time	One-way: 100ms, Return-way: 200ms (Recommended) One-way: 120ms, Return-way: 240ms		
Required bandwidth	control	100kbps	50kbps
	voice	Depending on the traffic	

Note: Including Secondary UNIT connection for Failover Mode

7. Software

Table 7-1 Software

Description	B Code	Feature	SV 8300	SV 8100
SC-4028 CYG-IPS BSC PROG-H1	---	SV8300 Generic Program for R6	X	-
SA-2131 CYG-IPS MAT PROG-IH1	---	SV8300 PCPro Program for R6	X	-

8. License

When installing the system and activating operational features beyond default system ports/features available initially, several licenses are required.

The required licenses (except System Version license) are combined and a license file is published on-line. The license file is loaded into the CPU blade and activated on-line.

Once the license file is loaded into the CPU blade and activated on-line, it cannot be used for any other systems (Copy protected).

Maximum 128 license files can be loaded into the CPU blade per system.

The following table shows license models available in SV8300.

Table 8-1 License

Category	Functions	Min	Max	License Model	SV 8300	SV 8100
System	Port Capacity	1	2048	LS-SYS-PORT CAPACITY-LIC	X	-
	VoIP Channels	16	6400	LS-SYS-IPPAD16-LIC (for US/AUS)	X	-
	System Version License R6	ON/OFF		LS-SYS-R6-LIC	X	-
	Dual CPU	ON/OFF		LS-SYS-DUAL CPU-LIC (for US/EU)	X	-
	Failover	ON/OFF		LS-SYS-FAILOVER-LIC	X	-
	Failover/Remote Extended License (30 days)	ON/OFF		LS-SYS-FO/RM 30 DAYS-LIC	X	-
	Failover/Remote Extended License (60 days)	ON/OFF		LS-SYS-FO/RM 60 DAYS-LIC	X	-
Extension	PS	1	512	LS-EXT-PHS-LIC	X	-
	D ^{term} IP (series i), DT700 series and MH240	1	1536	LS-EXT-IPPHONE-LIC	X	-
	SP30/SP350 Softphone	1	1536	LS-EXT-SP-LIC	X	-
	SP30/SP350 ACD	1	1536	LS-EXT-SP-ACD-LIC	X	-
	ISDN Terminal (B ch) (Note 1)	4	256	LS-EXT-ISDN-TERM-LIC	X	-
	Standard SIP Terminal	1	512	LS-EXT-STD-SIP-LIC	X	-
Trunk	SIP Trunk Channels	1	96	LS-TRK-SIP-LIC	X	-
	P2P CCIS Channels	1	512	LS-TRK-P2PCCIS-LIC	X	-
Network	Remote Sites (Remote UNIT over IP)	1	46	LS-NW-REMOTE-UNIT-LIC	X	-
	Mobility Access (MA) users	1	1536	LS-NW-MA-LIC	X	-

(to be continued in next page)

Table 8-1 License (cont'd)

Category	Functions	Min	Max	License Model (NEC Unified)	SV 8300	SV 8100
Feature	CCIS Feature	ON/OFF		LS-NW-CCIS-LIC	X	-
	PMS Feature	ON/OFF		LS-FEA-PMS-LIC	X	-
	OAI Feature	ON/OFF		LS-FEA-OAI-LIC	X	-
	SIP Trunk Feature	ON/OFF		LS-FEA-SIP-T-LIC	X	-
	PS Roaming Feature (US / Latin America only)	ON/OFF		LS-FEA-PHS-ROAM-LIC	X	-
	Embedded Conference Feature (32 Party)	8	32	LS-CONF-8PORT-LIC (up to three licenses available)	X	-
		8	32	LS-CONF-8PORT-LIC(OT) (up to four licenses available) (for Asia / Russia / Latin America)	X	-
	VoIP Encryption (Note2)	0	1000	LS-FEA-VOIP ENCRYPTION-LIC	X	-
In-skin UMS	UM8000 Mail View App Session	1	512	LKS-UMS-CLIENT1-LIC LKS-UMS-CLIENT4-LIC LKS-UMS-CLIENT8-LIC LKS-UMS-CLIENT16-LIC LKS-UMS-CLIENT32-LIC	X	X
	UM8000 Mail Ports	1	16	LKS-UMS-PORT4-LIC LKS-UMS-PORT8-LIC LKS-UMS-PORT16-LIC	X	X
	UM8000 Mail Multilanguage Support	1	23	LKS-UMS-LANGUAGE-LIC	X	X
	UM8000 Mail TTS for MS Outlook	1	6	LKS-UMS-TTS-PORT-LIC	X	X
	UM8000 Mail TTS Language	1	10	LKS-UMS-TTS-LANGUAGE-LIC	X	X
	UM8000 Mail FAX Port	1	4	LKS-UMS-FAX-LIC	X	X
	UM8000 Mail Hospitality / PMS	ON/OFF		LKS-UMS-HOTEL-PMS-LIC	X	X
	UM8000 Mail Hospitality Language	1	10	LKS-UMS-HOTEL-LANGUAGE-LIC	X	X
	UM8000 Mail Amis/Plus Net	ON/OFF		LKS-UMS-AMIS-PLUS-LIC	X	X
PVA Conference	SMB8000 Multimedia Conference Ports	8	128	LKS-PVA-CONF-PORT8-LIC	X	X

Note1: ISDN Terminal License

CD-2BRIA: 4 Licenses required

CD-2BRIA + PZ-2BRIA: 8 Licenses required

Note2: One LS-FEA-VOIP ENCRYPTION-LIC equals 1000 users.

The following table shows the required licenses for each feature.

Table 8-2 Required Licenses

Feature	License required (Note 1)	Hardware required (Note 2)	Remarks
Terminal Accommodation			
SLT	LS-SYS-PORT CAPACITY-LIC	LC Blade	
D ^{term} / DT300 series	LS-SYS-PORT CAPACITY-LIC	DLC Blade	
DSS Console (TDM)	LS-SYS-PORT CAPACITY-LIC	DLC Blade	
ISDN Terminal	LS-SYS-PORT CAPACITY-LIC LS-EXT-ISDN-TERM-LIC	ILC Blade	
ZT	LS-SYS-PORT CAPACITY-LIC	CSI Blade	
PS	LS-SYS-PORT CAPACITY-LIC LS-EXT-PHS-LIC		US and Latin America only
D ^{term} IP/DT700 series/MH240	LS-SYS-PORT CAPACITY-LIC LS-EXT-IPPHONE-LIC		
DSS Console (DT700 Side Option)	LS-SYS-PORT CAPACITY-LIC		
Standard SIP Terminal	LS-SYS-PORT CAPACITY-LIC LS-EXT-STD-SIP-LIC		
D ^{term} SP30 / SP350	LS-SYS-PORT CAPACITY-LIC LS-EXT-SP-LIC		
D ^{term} SP30 / SP350 ACD	LS-SYS-PORT CAPACITY-LIC LS-EXT-SP-ACD-LIC		
Virtual station	(Not required)		
Trunk Accommodation			
Analog Trunk	LS-SYS-PORT CAPACITY-LIC	Analog Trunk Blade	
ISDN Trunk	LS-SYS-PORT CAPACITY-LIC	PRT/BRT Blade	
QSIG Trunk	LS-SYS-PORT CAPACITY-LIC LS-NW-CCIS-LIC	PRT Blade	
CCIS-TDM	LS-SYS-PORT CAPACITY-LIC LS-NW-CCIS-LIC	CCT Blade	
CCIS-IP (P2P-CCIS)	LS-SYS-PORT CAPACITY-LIC LS-NW-CCIS-LIC LS-TRK-P2PCCIS-LIC		
SIP Trunk	LS-SYS-PORT CAPACITY-LIC LS-TRK-SIP-LIC LS-FEA-SIP-T-LIC		

(to be continued in next page)

Table 8-2 Required Licenses (cont'd)

Feature	License required (Note 1)	Hardware required (Note 2)	Remarks
Others			
Dual CPU	LS-SYS-DUAL CPU-LIC	Dual CPU Blades	US and EU only
Failover	LS-SYS-FAILOVER-LIC	Secondary UNIT	
Remote UNIT	LS-NW-REMOTE-UNIT-LIC		
Failover/Remote Extended License	LS-SYS-FO/RM xx DAYS-LIC		30 or 60 day license (System Max 60 Days)
PS Roaming (IP Roaming)	LS-SYS-PORT CAPACITY-LIC LS-TRK-P2PCCIS-LIC LS-NW-CCIS-LIC LS-FEA-PHS-ROAM-LIC		US and Latin America only
Embedded Conference (32 Party)	LS-CONF-8PORT-LIC		US, AUS and EU
	LS-CONF-8PORT-LIC(OT)		Asia, Russia and Latin America
VoIP Encryption	LS-FEA-VOIP ENCRYPTION-LIC		
Mobility Access (MA) user	LS-NW-MA-LIC		
PMS	LS-FEA-PMS-LIC		
OAI	LS-FEA-OAI-LIC		
UM8000	LS-SYS-PORT CAPACITY-LIC	In-skin UMS Blade	
UM8000 Mail View App Session	LKS-UMS-CLIENTx-LIC		
UM8000 Mail Ports	LKS-UMS-PORTx-LIC		
UM8000 Mail Multilanguage Support	LKS-UMS-LANGUAGE-LIC		
UM8000 Mail FAX Port	LKS-UMS-FAX-LIC		
UM8000 Mail Hospitality / PMS	LKS-UMS-HOTEL-PMS-LIC		
UM8000 Mail Hospitality Language	LKS-UMS-HOTEL-LANGUAGE-LIC		
UM8000 Mail Amis/Plus Net	LKS-UMS-AMIS-PLUS-LIC		
Conference Bridge	LS-SYS-PORT CAPACITY-LIC	Conference Bridge Blade	US and Australia only
SMB8000 Multimedia Conference Ports	LKS-PVA-CONF-PORT8-LIC		

(Note 1) System Version License is required to activate system version features.

(Note 2) Number of System Port Capacity Licenses required for the hardware is described in Table 8-3.

The following table shows the required System Port Capacity Licenses for each blade/daughter board.

Table 8-3 Required System Port Capacity Licenses

Category	Description	No. of Required System Port Capacity Licenses	Remarks
DLC	CD-8DLCA	8	
	PZ-8DLCB	8	
	CD-16DLCA	16	
LC	CD-4LCA	4	
	CD-8LCA	8	
	PZ-4LCA	4	
	PZ-8LCE	8	
COT	CD-4COTA	4	
	PZ-4COTE	4	
	CD-4COTC	4	
	PZ-4COTG	4	
	CD-4COTB	4	
	PZ-4COTF	4	
BRT/ILC	CD-2BRIA	4	
	PZ-2BRIA	4	
PRT/DTI	CD-PRTA	23 (Note)	PRI (23B+D) / QSIG
		30 (Note)	PRI (30B+D) / QSIG
		24	T1 DTI
		30	E1 DTI
CCT	CD-CCTA	23 (Note)	CCT (1.5M)
		30 (Note)	CCT (2M)
Analog Trunk	CD-4DIOPA	4	
	CD-4DIOPB	4	
	CD-4ODTA	4	
	CD-4ODTB	4	
CSI	CD-4CSIB-A	12	
APL	CD-RTB	-	
	CD-ETIA	-	
	CD-VM00	16	
	CD-PVAA	16	Conference Bridge
	CD-SVRU	-	

(Note) The number of System Port Capacity Licenses required is different from the number of actual Physical Ports shown in Table 4-2.

9. System Capacity

9.1 Traffic Capacity

The following shows the traffic capacity and its conditions of the SV8300 system.

- Maximum Traffic Capacity: 12,000 BHCA
- Traffic Conditions:
 - (1) $2n + m < 12,000$ BHCA
 - n: Call Traffic from DT700 series
 - m: Call Traffic from other terminals
 - (2) Call Mix
 - Outgoing Call: 30%
 - Incoming Call: 30%
 - Intra-office Call: 40%

9.2 System Port Capacity

The following table shows the system port capacity of the SV8300 system.

Table 9-1 System Port Capacity

Item		1 Unit			2 Units	3 Units	4 Units	System Max.				
		2U x 1	2U x 2	2U x 3	2U x 6	2U x 9	2U x 12	Standalone	Remote UNIT			
Blade Slots		6	12	18	36	54	72	72	900			
Port	Physical Port	108	216	324	648	972	1296	1296	2048	2048	2048	
	Virtual Port	1536			2048			2048		2048		
Physical Port	SLT (-28V)	96	192	288	576	864	1152	1152	1536	1536	1536	
	SLT (-48V)	24	48	72	144	216	288	288		1536		
	Digital Multiline Terminal (-48V) (D ^{term} series i / DT300 series)	96	192	288	576	864	1152	1152		1536		
	Digital Multiline Terminal (-48V) (DT300 series w/APR) (Note 1)	28 (28)	56 (56)	84 (84)	168 (168)	252 (252)	336 (336)	336 (336)		768 (768)		
	Digital Multiline Terminal (-48V) (D ^{term} series i w/APR) (Note 1)	21 (21)	42 (42)	63 (63)	126 (126)	189 (189)	252 (252)	252 (252)		768 (768)		
	DSS Console (for D ^{term} series i / DT300 series) (Note 2)	32						32		32		
	Desk Console (Note 4)	8						8		8		
	ISDN Terminal (BRI Bch) (Note 3)	48	96	144	256			256		256		
	ZT Interface (CSI) (ch) (Note 3)	48	96	144	288	384		384		384		
	In-skin UMS Port	48	96	128			128	128		128		
16-Party Conference w/ PVA (ch)	96	128				128	128	128				
Virtual Port	IP Multiline Terminal (D ^{term} IP series i)	1024			1536			1536	1536	1536		
	SIP Multiline Terminal (DT700)											
	Softphone											
	WiFi Handset (MH240)											
	PS	512					512	512				
	IP Single Line Telephone (SIP) (Standard SIP Terminal) (Note 4)	512										
DSS Console (for DT700 series) (Note 2)	32					32	32					
Physical Port	Central Office	COT	48	96	144	288	432	512	512	512	512	
	Trunk	DID	24	48	72	144	216	288		288		
	Tie Line Trunk	E&M	24	48	72	144	216	288		288		
	BRI Trunk (Note 3)		48	96	144	256		256		256		
	PRI Trunk (Note 6)	23B+D	96	192	288	504				504		504
		30B+D	93	186	279	496				496		496
	DTI Trunk	T1	96	192	288	504				504		504
		E1	90	180	270	510				510		510
CCIS Trunk (Note 6)	1.5M	96	192	288	384			384	384			
	2M	93	186	279	496			496	496			
Virtual Port	IP Trunk (P2P CCIS)	512					512	512	512			
	SIP Trunk (Note 4) (Note 8)	96					96	96	96			

Table 9-1 System Port Capacity (cont'd)

Item	1 Unit			2 Units	3 Units	4 Units	System Max.	
	2U x 1	2U x 2	2U x 3	2U x 6	2U x 9	2U x 12	Standalone	Remote UNIT
VoIP Channel w/ RTP	128			256	384	512	512	6400
Modem Channel (Note 4)	1						1	1
VRS Message (Note 4)	8						8	8
DTMF Sender	64						64	64
Caller ID Sender (FSK)	16						16	16
DTMF Receiver (Note 5)	32						32	32
MF Sender (Note 4, 5)	32						32	
MF Receiver (Note 5)	32						32	
Caller ID Receiver (FSK) (Note 5)	32						32	
Caller ID Receiver (DTMF) (Note 5)	32						32	
MFC Sender (Note 5)	16						16	
MFC Receiver (Note 5)	16						16	
3-/4-Party Conference (ch)	64			128			128	
32-Party Conference (ch) (Note 7)	32						32	

Note 1 When using DT300/Dterm with APR (Dual Port Mode), the physical ports for analog station shown in parenthesis are required in addition to the physical ports for Multiline Terminal.

Note 2 The total number of following DSS Consoles is maximum 32 per system.

- DSS Console (for D^{term} series i / DT300 series)
- DSS Console (for DT700 series)

Note 3 The required number of ports per blade is shown in Table 4-2.

(e.g. CD-2BR1A + PZ-2BR1A: 8 ports, CD-4CSIB-A: 12 ports)

Note 4 Available at main unit (UNIT01) only.

Note 5 The total number of following functions is maximum 32 per system.

- DTMF Receiver
- Caller ID Receiver (FSK)
- Caller ID Receiver (DTMF)
- MFC Sender
- MFC Receiver
- MF Sender
- MF Receiver

Note 6 The number of System Port Capacity Licenses required is different from the number of actual Physical Ports consumed. Refer to Table 8-2.

Note 7 The following conference groups can be configured.

- One, 32-party conference group
- Two, 16-party conference groups
- Four, eight-party conference groups

Note 8 In case of call from/to TDM terminal via SIP trunk, maximum 96 calls can be established at the same time, because one VoIPDB channel is occupied per call.

In case of call from/to IP terminal via SIP trunk, maximum 64 calls can be established at the same time, because two VoIPDB channels are occupied per call.

Please refer to Table 4-5.

Appendix 1: MTBF

Category	Description	FIT	MTBF (Years)
for 1U Chassis / 2U CP Chassis			
Chassis	SN1752 CYGMB	11482	9.9
	SN1764 CYGME	18851	6.1
CPU	CC-CP00 (discontinued)	15836	7.21
	CC-CP31	15836	7.21
	CC-CP01	15985	7.14
BUS	PZ-BS10	3670	31.1
VM	PZ-VM21	7610	15.0
VoIP	PZ-64IPLA	1654	69.0
	PZ-128IPLA	1972	57.8
for 2U Chassis			
Chassis	SN1750 CYGMA	17598	6.5
BUS	PZ-BS11	1606	71.1
DLC	CD-8DLCA	4985	22.9
	PZ-8DLCB	4963	23.0
	CD-16DLCA	6876	16.6
LC	CD-4LCA	3377	33.8
	CD-8LCA	4717	24.2
	PZ-4LCA	1520	75.1
	PZ-8LCE	2861	39.9
COT	CD-4COTA	3658	31.2
	PZ-4COTE	2942	38.8
	CD-4COTC	3658	31.2
	PZ-4COTG	2942	38.8
	CD-4COTB	3866	29.5
	PZ-4COTF	3281	34.7
BRT/ILC	CD-2BR1A	14825	7.7
	PZ-2BR1A	11530	9.9
PRT/DTI	CD-PRTA	8988	12.7
CCT	CD-CCTA	8988	12.7
Analog Trunk	CD-4D1OPA	5239	21.7
	CD-4D1OPB	5239	21.7
	CD-4ODTA	4956	23.0
	CD-4ODTB	4956	23.0
CSI	CD-4CSIB (discontinued)	6474	17.6
	CD-4CSIB-A	6692	17.1
APL	CD-RTB	5004	22.8
	CD-ETIA	12228	9.3
	CD-VM00	3596	31.7
	CD-PVAA	12520	9.1
	CD-SVRU	4919	23.2

Appendix 2: Maximum Power Consumption

Category	Description	Max. Power Consumption (mA)				Remarks
		3.3V	5V	-28V	-48V	
for 1U Chassis / 2U CP Chassis						
Chassis	SN1752 CYGMB	-	-	-	-	
	SN1764 CYGME	-	-	-	-	
CPU	CC-CP00 (discontinued)	-	-	-	-	1420mA with 12V
	CC-CP31	-	-	-	-	1420mA with 12V
	CC-CP01	-	-	-	-	1420mA with 12V
BUS	PZ-BS10	240	-	-	-	
VM	PZ-VM21	220	-	-	-	
VoIP	PZ-64IPLA	1200	-	-	-	
	PZ-128IPLA	1800	-	-	-	
for 2U Chassis						
Chassis	SN1750 CYGMA	-	-	-	-	
BUS	PZ-BS11	80	-	-	-	
DLC	CD-8DLCA	120	-	-	420	
	PZ-8DLCB	70	-	-	420	
	CD-16DLCA	180	-	-	840	
LC	CD-4LCA	180	10	110	-	
	CD-8LCA	290	10	200	-	
	PZ-4LCA	160	20	120	-	
	PZ-8LCE	260	10	200	-	
COT	CD-4COTA	80	80	40	-	
	PZ-4COTE	50	20	40	-	
	CD-4COTC	80	80	40	-	
	PZ-4COTG	50	20	40	-	
	CD-4COTB	80	80	40	-	
	PZ-4COTF	50	20	40	-	
BRT/ILC	CD-2BRIA	400	10	-	10	Note
	PZ-2BRIA	360	10	-	10	Note
PRT/DTI	CD-PRTA	180	100	-	-	
CCT	CD-CCTA	180	100	-	-	
Analog Trunk	CD-4DIOPA	100	20	230	-	
	CD-4DIOPB	100	20	230	-	
	CD-4ODTA	80	30	120	-	
	CD-4ODTB	80	30	120	-	
CSI	CD-4CSIB (discontinued)	330	240	-	400	
	CD-4CSIB-A	330	240	-	400	
APL	CD-RTB	2840	350	-	-	
	CD-ETIA	1640	-	-	-	
	CD-VM00	700	200	100	-	
	CD-PVAA	1000	500	-	-	
	CD-SVRU	2000	-	800	-	

Note: Power consumption for power supply to connected ISDN terminals is not considered.

Appendix 3: Cable Length of Terminals

Terminal	Cable		Cable Length between SV8300 and Terminal	Remarks
	Kind of Cable	Pair		
D ^{term} Series-i / DT300 Series Note	Twisted Pair Cable	1-pair	400m (1312ft) with 26 AWG	Same with or without AC adapter
			600m (1968ft) with 24 AWG	
			800m (2625ft) with 22 AWG	
DT700 Series	LAN Cable (UTP cable 10BASE-T/100BASE-TX)	2-pair	100m (328ft) or less	Same with or without AC adapter
Analog Telephone (SLT, G3FAX etc.)	Twisted Pair Cable	1-pair	1000m (3281ft) with 26 AWG	Loop Resistance : Max. 600 ohms (including telephone set)
			1500m (4921ft) with 24 AWG	
			2500m (8202ft) with 22 AWG	
Long Line Telephone	Twisted Pair Cable	1-pair	4000m (13123ft) with 26 AWG	Loop Resistance : Max. 1500 ohms (including telephone set)
			6400m (20997ft) with 24 AWG	
			10600m (34777ft) with 22 AWG	
ISDN Terminal / G4FAX	Twisted Pair Cable	2-pair	100m (328ft) with 24 AWG	P-MP Connection (Short Passive Bus)
			300m (984ft) with 24 AWG	P-MP Connection (Extended Passive Bus) Distance between ISDN terminals : 50m (164ft) with 24AWG
			500m (1640ft) with 24 AWG	P-P Connection
ZT	Twisted Pair Cable	1-pair	260m (853ft) with 26 AWG	PBX Power Supply (-48V)
			410m (1345ft) with 24 AWG	
			680m (2231ft) with 22 AWG	
		2-pair	520m (1706ft) with 26 AWG	PBX Power Supply (-48V)
			820m (2690ft) with 24 AWG	
			1360m (4462ft) with 22 AWG	
3000m (9842ft)	Local Power Supply			
DSS Console (for D ^{term} series i / DT300 series)	Twisted Pair Cable	1-pair	400m (1312ft) with 26 AWG	
			600m (1968ft) with 24 AWG	
			800m (2625ft) with 22 AWG	
Analog Power Failure Adapter (PSA)	Twisted Pair Cable	1-pair	Depending on Loop Resistance	Loop Resistance : Max. 1700 ohms (including the PSA [400 ohms])
Paging Adapter	Twisted Pair Cable	1-pair	600m (1968ft) with 26 AWG	
			800m (2625ft) with 24 AWG	
			800m (2625ft) with 22 AWG	
Desk Console w/ AC Adapter	Twisted Pair Cable	1-pair	400m (1312ft) with 26 AWG	
			600m (1968ft) with 24 AWG	
			800m (2625ft) with 22 AWG	

Terminal	Cable		Cable Length between SV8300 and Terminal	Remarks
	Kind of Cable	Pair		
SMDR / PMS (RS-232C)	RS-232C Cable (RS RVS-15S CA-F)	-	15m (49ft)	
SMDR / PMS (LAN)	LAN Cable (UTP cable 10BASE-T/100BASE-TX)	2-pair	100m (328ft) or less	
Hotel Server	LAN Cable (UTP cable 10BASE-T/100BASE-TX)	2-pair	100m (328ft) or less	
Printer	RS-232C Cable (RS PRT-15S CA-F)	-	15m (49ft)	

Note When the terminal type is DT330 (Desi-less) without AC adapter and it has both bottom and cradle options, the cable length is as follows.

- 250m (820ft) with 26AWG
- 400m (1312ft) with 24AWG
- 500m (1640ft) with 22AWG